

On the Analysis of using 3-coil Wireless Power Transfer System in Retinal Prosthesis

Shun Bai^{*†} and Stan Skafidas^{*}

Abstract—Designing a wireless power transmission system(WPTS) using inductive coupling has been investigated extensively in the last decade. Depending on the different configurations of the coupling system, there have been various designing methods to optimise the power transmission efficiency based on the tuning circuitry, quality factor optimisation and geometrical configuration. Recently, a 3-coil WPTS was introduced in retinal prosthesis to overcome the low power transferring efficiency due to low coupling coefficient. Here we present a method to analyse this 3-coil WPTS using the S-parameters to directly obtain maximum achievable power transferring efficiency. Through electromagnetic simulation, we brought a question on the condition of improvement using 3-coil WPTS in powering retinal prosthesis.

I. INTRODUCTION

As wireless technology develops, inductively coupled WPTS [1] have been applied into biomedical devices such as neuromuscular stimulators, cochlear implants and visual prostheses, in which there is no battery at receiver side and power is transferred from an external portable unit. Despite all the coupling modes, geometries, coupling distances and power consumption requirements, these systems follow the same design target which is to maximise power transmission efficiency in order to minimise the energy loss during the transferring of power, eliminate overheating in both transmitter and receiver side and thus lengthen battery lifetime of the energy source.

In applying WPTS to the recent retinal prostheses [2], [3] for treating age-related macular degeneration (AMD) and retinitis pigmentosa (RP), the very limited space inside the eye becomes a key factor limiting the power efficiency in designing WPTS. There have been several design procedures proposed using analytical and electromagnetic modelling methods [4] and equivalent circuit analysis [5], [6]. These methods make assumptions about circuit model and topology that are used to represent the specific real components and require additional measurements for various parameters such as coupling coefficient or quality factor to take into account of skin effect, proximity effect, radiation loss, near field approximation and parasitic components to accurately reflect the physical components in a WPTS [7]–[9]. As in [1], there is a detailed analysis on how to measure the quality factor of coils, coupling coefficients, and how to determine the inductive wireless power transmission efficiency. However, these methods do not allow a direct or convenient way to assess the variations of power transferring efficiency

due to current loading condition, different coil geometries and relative placements. These methods also do not apply directly to other coupling modes such as capacitively coupled wireless power transfer.

In this paper, we present an analysis based on widely accepted transducer power gain concept used in RF theory which treats the WPTS as a general n-port network and explain how to evaluate power transferring efficiency in various coupling designs by converting scattering parameters into traditional circuitry parameters, to find the optimum power transferring conditions. This method is applicable to characterise various coupling designs using coils for power transferring and can also be applied directly to reduce the design iterations by using both vector network analyser and/or electromagnetic simulation software such as HFSS. In particular, we investigated the technique of introducing a third coil at resonance to improve the power transferring efficiency as proposed in [10]–[12]. The question on conditions for improvement by using 3-coil WPTS is discussed.

II. ANALYSIS

A. Overview of scattering parameter

Similar to impedance or admittance matrixes Z and Y that uniquely define the relations between current and voltage at the terminals of a n-port network, scattering parameters (S-parameters) can also be used to uniquely describe an electrical network's response to various inputs. Impedance parameters Z matrix defines the terminal voltages by $V = ZI$ when the terminal currents are given. Similarly, S-parameters relate the reflected travelling waves to the incident travelling waves by

$$\mathbf{b} = \mathbf{S}\mathbf{a} \quad (1)$$

where \mathbf{a} and \mathbf{b} are phasor representation of incident wave vector and reflected wave vector respectively, and they can be related to the terminal voltage and current vectors using linear transformation by

$$\begin{cases} \sqrt{Z_0}\mathbf{a} = (\mathbf{V} + Z_0\mathbf{I})/2 \\ \sqrt{Z_0}\mathbf{b} = (\mathbf{V} - Z_0\mathbf{I})/2 \end{cases} \quad (2)$$

Following this symbolic convention, the power associated with the travelling wave incident at port i can be directly represented¹ as $\frac{1}{2}\mathbf{a}_i\mathbf{a}_i^*$ as analogous to $\frac{1}{2}VI^*$ when using voltage and current to calculate the power [13].

^{*}S. Bai and S. Skafidas is with Center For Neural Engineering, The University of Melbourne, Parkville, Victoria 3010, Australia

[†]Email: shbai at unimelb.edu.au

¹The bold fonts \mathbf{a} and star symbol a^* in this paper will be used to represent a matrix and conjugation of a complex number respectively.

B. Derivation of coupling coefficient and quality factor

To convert from S-parameters to conventional circuit model such as coupling coefficient and quality factor, the S-parameters can be converted to impedance matrix as given by (3).

$$\mathbf{Z}_0(\mathbf{S}+\mathbf{I})(\mathbf{I}-\mathbf{S})^{-1}=\mathbf{Z} \quad (3)$$

where \mathbf{I} denotes the identity matrix. Consider the inductively coupled pair of coil as a two-port network shown in the Fig.1 below, the impedance matrix can be represented, to the first

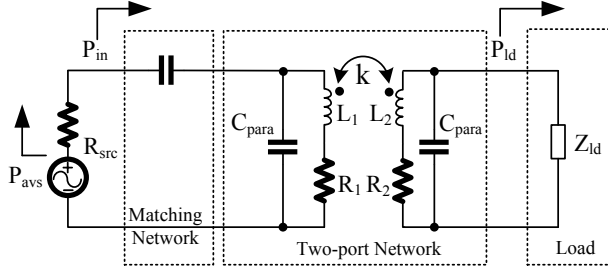

Fig. 1. Typical circuit model for WPTS

order when the interested frequency is much lower than the coil's self resonance frequency, as

$$\mathbf{Z}=\left(\begin{array}{cc} Z_{11} & Z_{12} \\ Z_{21} & Z_{22} \end{array}\right)=\left(\begin{array}{cc} R_1+j\omega L_1 & j\omega k\sqrt{L_1 L_2} \\ j\omega k\sqrt{L_1 L_2} & R_2+j\omega L_2 \end{array}\right) \quad (4)$$

where the parasitic capacitance of C_{para} could be ignored, coupling coefficient k can be evaluated as [14]:

$$k=\frac{\sqrt{\operatorname{Im}\left(Z_{12}\right) \operatorname{Im}\left(Z_{21}\right)}}{\sqrt{\operatorname{Im}\left(Z_{11}\right) \operatorname{Im}\left(Z_{22}\right)}} \quad (5)$$

and quality factor for each coil can be evaluated as

$$Q_i=\frac{\operatorname{Im}\left(Z_{ii}\right)}{\operatorname{Re}\left(Z_{ii}\right)} \quad (6)$$

C. Derivation of power transferring efficiency

The power transferring efficiency was analysed intensively in the recent literatures [9], [11], [12] which all cited from Baker's paper [8]. Unfortunately, in deriving the optimal loading condition, this paper got incorrect result when differentiating equation (13) w.r.t Q_L , hence the wrong result of η_{MAX} . Actually, to calculate the power transferring efficiency which is defined as in Fig.1:

$$\eta=\frac{P_{ld}}{P_{in}} \quad (7)$$

it is exactly the same as the commonly used in RF theory to characterise the power gain in power amplifier [15]. The same result is also applicable to this inductively coupled two-port network, which is passive instead of active, therefore is unconditionally stable and has a maximum power gain, i.e. maximum power transferring efficiency as:

$$\eta_{MAX}=G_{p, \max }=G_{T, \max }=\frac{\left|S_{21}\right|}{\left|S_{12}\right|}\left(K-\sqrt{K^2-1}\right) \quad (8)$$

where K is defined as

$$K=\frac{1-\left|S_{11}\right|^2-\left|S_{22}\right|^2+\left|S_{11} S_{22}-S_{12} S_{21}\right|^2}{2\left|S_{12} S_{21}\right|} \quad (9)$$

which is also known as Rollet's stability factor satisfying:

$$K>1 \quad (10)$$

for all passive two-port network. If the coupling coefficient and quality factor are substituted, the maximum power transferring efficiency can also be represented as:

$$\eta_{MAX}=\left(\sqrt{1+\frac{1}{k^2 Q_1 Q_2}}-\sqrt{\frac{1}{k^2 Q_1 Q_2}}\right)^2 \quad (11)$$

D. Converting 3-port network to 2-port network

To apply the above derived results into the 3-coil WPTS, we consider the 3-coil WPTS as a 3-port network with certain termination Z_3 at port 3 to form a new 2-port network. We transform the termination at port 3 Z_3 into reflection

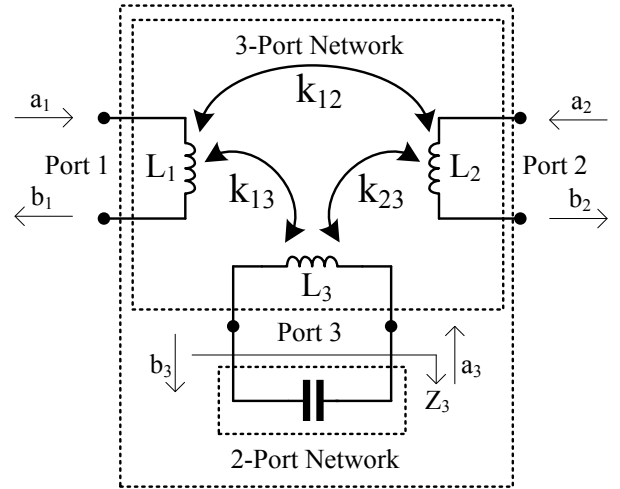

Fig. 2. Formation of 2-port network from 3-port network

parameter Γ_3 by

$$\Gamma_3=\frac{Z_3-Z_0}{Z_3+Z_0} \quad (12)$$

From the definition of S-parameters in Eq.(1),

$$\begin{pmatrix} b_1 \\ b_2 \\ b_3 \end{pmatrix}=\begin{pmatrix} S_{11} & S_{12} & S_{13} \\ S_{21} & S_{22} & S_{23} \\ S_{31} & S_{32} & S_{33} \end{pmatrix}\begin{pmatrix} a_1 \\ a_2 \\ a_3 \end{pmatrix} \quad (13)$$

With the reflection condition Γ_3 at port 3 as:

$$b_3=\Gamma_3 a_3 \quad (14)$$

then the new 2-port network's S-parameter can be solved as

$$\begin{pmatrix} b_1 \\ b_2 \end{pmatrix}=\begin{pmatrix} S_{11}+\frac{S_{13} S_{31}}{\Gamma_3-S_{33}} & S_{12}+\frac{S_{13} S_{32}}{\Gamma_3-S_{33}} \\ S_{21}+\frac{S_{23} S_{31}}{\Gamma_3-S_{33}} & S_{22}+\frac{S_{23} S_{32}}{\Gamma_3-S_{33}} \end{pmatrix}\begin{pmatrix} a_1 \\ a_2 \end{pmatrix} \quad (15)$$

Obviously, there are additional terms that are added to the original S_{ij} entries as new S'_{ij} for 2-port network:

$$S'_{ij}=S_{ij}+\frac{S_{i3} S_{3j}}{\Gamma_3-S_{33}} \quad (16)$$

By applying derived results for two-port network, the power transferring efficiency in 3-coil WPTS is then calculated in straight forward.

III. RESULTS

We have built a 3D model setup for verifying the efficacy of introducing the third coil in resonance using ANSYS HFSS (High-Frequency structural simulator). The question to ask is whether an additional coil placed between the two coils will enhance the power transfer efficiency when it is tuned to the resonant frequency by connecting a proper capacitor to this additional coil. As shown in Fig. 3 below, two coils with the same dimensions of radius of 4mm are placed with axis aligned with separation of 5mm.

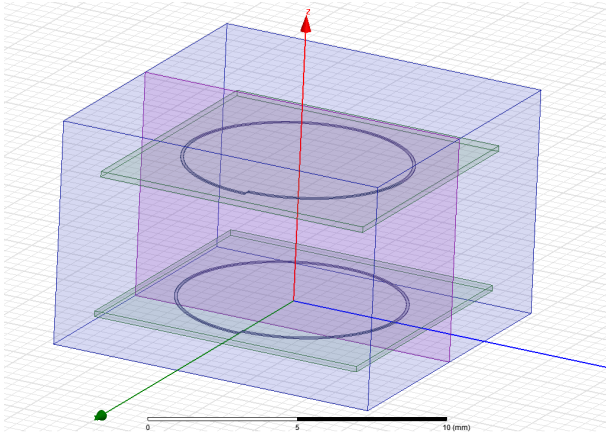

Fig. 3. 2 coils setup as a two-port network (original)

In order to introduce the resonance at proper frequency, a structure representing a parallel capacitor using very high relative permittivity (around 30000 ~ 50000, because only one turn coil was used) was constructed and connected in series with the third coil which was placed in between the existing two coils as shown in Fig. 4. It shifted the resonant

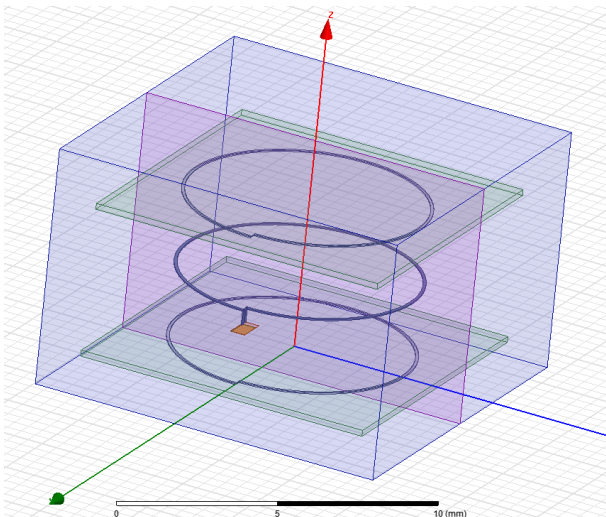

Fig. 4. Third coil in resonance with parallel capacitor (capK)

frequency at the third coil to roughly 10MHz. The exact value of the capacitance was tested by using a parametric sweep of the relative permittivity of the dielectric material. In order to minimise the influence of this additional capacitor's metal plates on the coupling field calculation, this capacitor's plate sizes were limited to 0.76mm by 0.46mm with distance of 0.01mm. From the analytical formula for parallel plates capacitor, the capacitance was around 10nF where the single loop coil's inductance is around 26nH.

As comparison, another setup was constructed to see whether this 3-coil is actually more effective than a two-coil system but with reduced distance between the existing two main coils, as shown in Fig. 5, the RX coil was moved closer to where the resonant was placed (2.5mm between TX and RX coils)

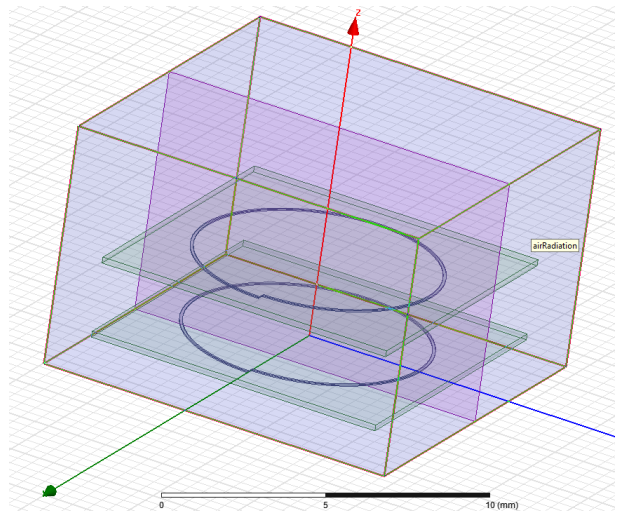

Fig. 5. Two coils with reduced distance (MidCoil)

By applying the formulas derived in previous section as Eq.(8), the maximum power transferring efficiency was directly calculated from the S-parameter results at the frequency range from 1MHz to 100MHz.

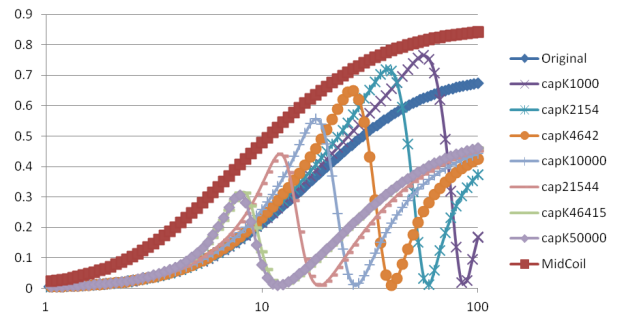

Fig. 6. Maximum power transferring efficiency

As shown in Fig.6, three testing configurations' results were plotted together with horizontal axis representing frequency in MHz, and vertical axis representing maximum power transferring efficiency (i.e. 0.5 represents $\frac{P_{d}}{P_{in}}|_{MAX} =$

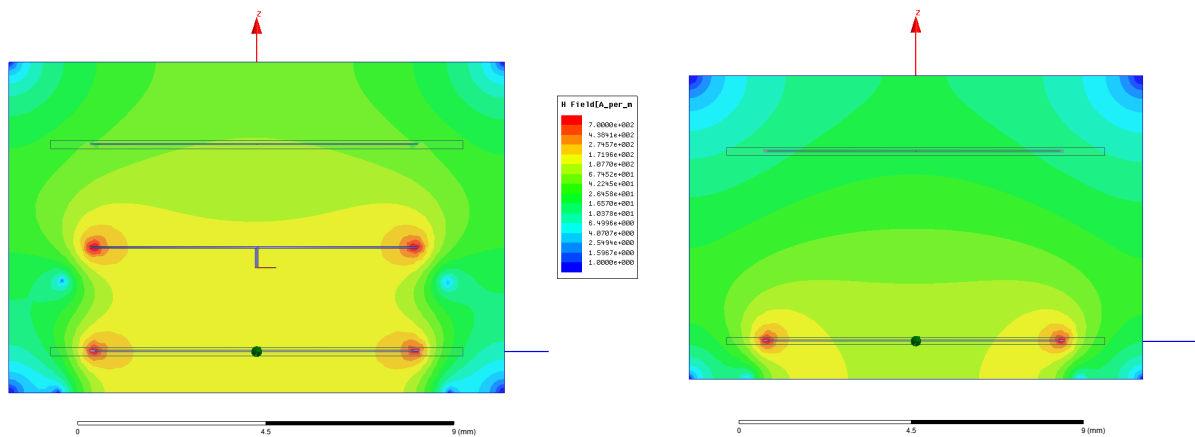

Fig. 7. H Field plot showing coupling enhancement

50%). At 10MHz, 3-coil WPTS had two times higher maximum power transferring efficiency when the resonance frequency was correctly tuned to the frequency under operation. It however had a side-effect at reducing the power transferring efficiency at higher frequencies. The boost of efficiency is at the cost of reducing those possible power transferring efficiency at those high frequency bands. When 3-coil WPTS was compared with the situation where the distance was reduced to where the resonant coil was placed, interestingly, the maximum power transferring efficiency in 2-coil WPTS was actually higher than, no matter how the resonant coil was tuned, the 3-coil WPTS.

In Fig.7, the magnetic fields were plotted to show how the third coil in resonance frequency enhances the coupling between the TX (in bottom) and RX (in top) coils when the distance between them was fixed. In the same field strength legends, the H field near the RX coil plane was much higher than the case without the resonant coil.

IV. CONCLUSION

Given a two-port network used for WPTS, the maximum efficiency was directly analysed using S-parameters. In addition to maximising power efficiency for two-port network, by employing resonant capacitor termination at the third port, the power transferring efficiency for 3-coil WPTS was derived and tested using HFSS. The calculation using S-parameters can be programmed to be shown directly on display on the fly during measurement or be optimised as figure of merit during the design of coils. With this method, it was shown that 3-coil WPTS indeed improves the power transferring efficiency under the condition that the resonant coil is correctly tuned, although it sacrifices the efficiency at higher frequency bands. The results also showed that when there is a possibility to place the TX coil closer, it is always better to do so than using a third-coil in resonance.

REFERENCES

[1] M. Ghovanloo and S. Atluri, "A wide-band power-efficient inductive wireless link for implantable microelectronic devices using multiple carriers," *Circuits and Systems I: Regular Papers, IEEE Transactions on*, vol. 54, no. 10, pp. 2211–2221, Oct. 2007.

[2] M. Monge, M. Raj, M. Nazari, H.-C. Chang, Y. Zhao, J. Weiland, M. Humayun, Y.-C. Tai, and A. Emami, "A fully intraocular high-density self-calibrating epiretinal prosthesis," *Biomedical Circuits and Systems, IEEE Transactions on*, vol. 7, no. 6, pp. 747–760, Dec 2013.

[3] Y.-K. Lo, K. Chen, P. Gad, and W. Liu, "A fully-integrated high-compliance voltage soc for epi-retinal and neural prostheses," *Biomedical Circuits and Systems, IEEE Transactions on*, vol. 7, no. 6, pp. 761–772, Dec 2013.

[4] U. Jow and M. Ghovanloo, "Design and optimization of printed spiral coils for efficient transcutaneous inductive power transmission," *Biomedical Circuits and Systems, IEEE Transactions on*, vol. 1, no. 3, pp. 193–202, 2007.

[5] W. Ko, S. Liang, and C. Fung, "Design of radio-frequency powered coils for implant instruments," *Medical and Biological Engineering and Computing*, vol. 15, no. 6, pp. 634–640, 1977.

[6] S. Bai, D. C. Ng, E. Skafidas, and I. M. Y. Mareels, "Generalized maximum efficiency theory on multi-stage inductive coupling," in *Proc. Progress in Electromagnetics Research Symposium, PIERS*, 2010, pp. 245–250.

[7] G. Felic, D. Ng, and E. Skafidas, "Investigation of frequency-dependent effects in inductive coils for implantable electronics," *Magnetics, IEEE Transactions on*, vol. 49, no. 4, pp. 1353–1360, April 2013.

[8] M. Baker and R. Sarpeshkar, "Feedback analysis and design of rf power links for low-power bionic systems," *Biomedical Circuits and Systems, IEEE Transactions on*, vol. 1, no. 1, pp. 28–38, March 2007.

[9] A. RamRakhyani and G. Lazzi, "Multicoil telemetry system for compensation of coil misalignment effects in implantable systems," *Antennas and Wireless Propagation Letters, IEEE*, vol. 11, pp. 1675–1678, 2012.

[10] Y. Zhao, M. Nandra, C.-C. Yu, and Y. chong Tai, "High performance 3-coil wireless power transfer system for the 512-electrode epiretinal prosthesis," in *Engineering in Medicine and Biology Society (EMBC), 2012 Annual International Conference of the IEEE*, Aug 2012, pp. 6583–6586.

[11] M. Kiani, U.-M. Jow, and M. Ghovanloo, "Design and optimization of a 3-coil inductive link for efficient wireless power transmission," *Biomedical Circuits and Systems, IEEE Transactions on*, vol. 5, no. 6, pp. 579–591, Dec 2011.

[12] A. RamRakhyani, S. Mirabbasi, and M. Chiao, "Design and optimization of resonance-based efficient wireless power delivery systems for biomedical implants," *Biomedical Circuits and Systems, IEEE Transactions on*, vol. 5, no. 1, pp. 48–63, Feb 2011.

[13] AN95, *S-Parameter Techniques for Faster, More Accurate Network Design*, Agilent Technologies, <http://contact.tm.agilent.com/Agilent/tmo/an-95-1/index.html>.

[14] D. Ng and E. Skafidas, "Coupling invariant inductive link for wireless power delivery to a retinal prosthesis," in *Engineering in Medicine and Biology Society (EMBC), 2013 35th Annual International Conference of the IEEE*, July 2013, pp. 3250–3253.

[15] A. M. Niknejad, *Electromagnetics for high-speed analog and digital communication circuits*. Cambridge University Press Cambridge, 2007.