

Fibre-Selective Discrimination of Physiological ENG Using Velocity Selective Recording: Report on Pilot Rat Experiments

Benjamin Metcalfe, Daniel Chew, Chris Clarke, Nick Donaldson and John Taylor

Abstract — This paper presents results from a pilot experiment in which the technique of *velocity selective recording* (VSR) was used to identify naturally occurring *electroneurogram* (ENG) signals within the intact nerve of a rat. Signals were acquired using a set of electrodes placed along the length of the nerve, formed from simple wire hooks. This basic form of recording has already been applied *in-vivo* to the analysis of electrically excited *compound action potentials* (CAPs) in both *pig* and *frog*, however, this method has never before been used to identify naturally occurring neural signals. Results in this paper highlight challenges which must be overcome in order for the transition to be made from electrically evoked potentials to naturally occurring signals.

I. INTRODUCTION

The well understood relationship between nerve fibre diameter and *conduction velocity* (CV) was first described by Erlanger and Gasser in 1937 [1]. The time taken for an *action potential* to travel a known distance along an axon can be accurately measured and used to calculate the intrinsic conduction velocity of the axon. While it is possible to calculate CV using only a single pair of electrodes (a dipole) it has been shown that the velocity selectivity of a system can be increased by using multiple electrodes [2]. The use of *velocity selective recording* (VSR) enables discrimination of action potentials based both on direction of propagation (*afferent* or *efferent*) and CV, without the need to submit the nerve to invasive and potentially damaging procedures [3], [4]. This method provides a viable interface for neural recording systems that have potential use in a range of prosthetic devices. In addition, information about conduction velocity is potentially useful for neuroscientists wishing to study nerve conduction disorders.

Velocity discrimination has the potential to extract useful physiological information, such as bladder fullness [5]. However, although *multiple electrode cuffs* (MECs) have been used to record electrically evoked *compound action potentials* (CAPs) [6], [7], VSR has, until now, not been demonstrated with naturally-occurring neural signals. This paper presents experimental data that supplements and extends earlier work using CAPs as described in [6] and [7] and provides the first practical demonstration of the application of VSR to naturally-occurring ENG. Unlike the recordings reported in [2] – [4] which use MECs, the

experiments described in this paper used an array of *hook* electrodes. This allowed individual ENG spikes to be observed and counted, providing verification for the VSR process. This work is described in a companion paper [12].

II. EXPERIMENTAL METHODS

A. Recording Setup

A recording array comprising of a set of tungsten wire hooks was used to record neural signals from an intact nerve within a dorsal root of a *rat*. The resulting data were amplified and filtered before being stored for offline analysis. During the course of the experiment modulation of the neural signals was elicited by stimulating the L5 dermatome both manually (*via* direct cutaneous stimulation) and electrically (*via* a single wire electrode).

B. Recording and Stimulation Electrodes

The recording electrode was fabricated on site and contained a total of six hooks supported by a clamp stand. Each hook was formed from 0.2 mm diameter tungsten wire, fed through a polyurethane tube of 0.4 mm (internal) diameter. The wire was supported within each tube by an application of cyanoacrylate adhesive at each end. The hooks were formed at one end by winding around a pre-existing cylinder of 4 mm diameter; the shape of each hook was maintained by the rigidity of the wire. The total length of the electrode array was 5 mm.

C. Surgical Procedure

All animal procedures were performed in accordance with the United Kingdom Animal (Scientific Procedures) Act 1986. An adult female Sprague Dawley rat (250 grams) was anaesthetised with 1.5 g/kg urethane (Sigma) administered by the *intraperitoneal* route. The dorsal spinal cord was exposed *via* a laminectomy of three of the lumbar spinal vertebrae. The dorsal skin was sutured to an overhanging rectangular bar, creating a contained pool into which non-conductive mineral oil was poured. The *dura* was incised to expose the dorsal roots.

The left fifth lumbar dorsal root (L5) was teased apart into fine fascicles with fine glass pulled pipettes, in a method described previously [8]. One fascicle, that was approximately 100 μm in diameter, was placed over all of the hooks in the array. The electrodes were arranged in a bipolar configuration (Fig. 1) for connection to the recording set-up (Digitimer, UK) and the animal was suitably electrically grounded. The six hooks were connected to five

Benjamin Metcalfe (corresponding author b.w.metcalfe@bath.ac.uk), Chris Clarke and John Taylor are with the Department of Electronic and Electrical Engineering, University of Bath, Bath BA2 7AY UK.

Daniel Chew is with the Cambridge Centre for Brain Repair, University of Cambridge, Cambridge, CB2 0PY, UK.

Nick Donaldson is with the Department of Medical Physics and Bioengineering, University College London, London WC1 UK.

respective pre-amplifier head-stages (Neurolog NL100), following the direction of action potential propagation. For each head-stage the signal was pre-amplified 1000 times using an AC coupled amplifier (Neurolog NL104A) fed through a 50 Hz noise eliminator (Humbug, Quest Scientific, Canada) and amplified 10 times further (Neurolog NL106) before band pass filtering at 200-5000 Hz. The total system gain was 10,000. Stimulation was applied by lightly brushing the L5 dermatome, or by applying a 1 mA square wave current pulse (width 1 ms) that also triggered the recording. An increase in afferent activity was visually observable in the concurrent recordings during cutaneous stimulation. A number of different fascicles that were teased from the L5 root were examined for afferent activity before selection of a single fascicle was made.

D. Recording Electronics & Data Analysis

The amplified and filtered signal was passed to a set of high speed ADCs (NI9222 mounted in cDAQ-9178 by National Instruments, Austin, TX, USA) providing simultaneous sampling of all five bipolar recordings at a maximum sample rate of 500 kS/s and a digital resolution of 16 bits. The maximum analogue input range was +/- 10V. The converters were connected to a laptop computer running LabView 2010 that logged each channel into a set of data files for offline analysis. Online visual verification was provided by connecting a set of oscilloscope channels in-line with the converter which provided a means to examine each recording in real time for artefacts or noise. Offline data analysis was performed using MATLAB R2012b (The MathWorks, Natick, MA, USA).

A simple process called *delay-and-add* was used to extract the basic velocity information from the raw data, the recordings lasting 250 ms [3], [9]. The channels are delayed relative to the first channel V_{B1} by an interval that depends on both the electrode spacing and the propagation velocity of the signal. So if the delay between the first two channels (V_{B1}, V_{B2}) is dt the delay between the first and third channels (V_{B1}, V_{B3}) is $2 \cdot dt$ and so on. Delay-and-add operates by inserting variable delays into the channels to effectively cancel the naturally occurring delays after which the channels are summed resulting in a single signal V_D (1)

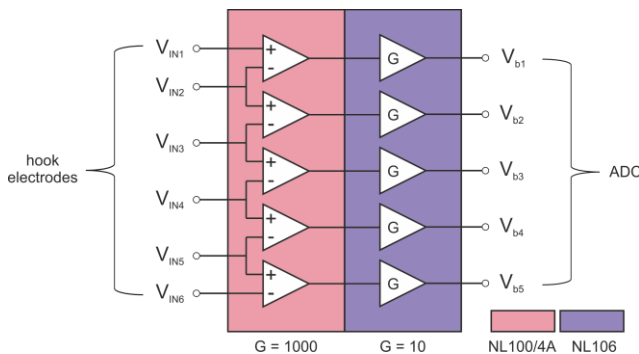

Figure 1: Simplified sketch of the amplifier configuration used to extract five bipolar signals from six electrode contacts.

$$V_D(t, dt) = \sum_{i=1}^5 V_{Bi}(t(i-1) \cdot dt) \quad (1)$$

The value of dt can now be swept for the range of velocities that are of interest. For each value of dt the maximal value of V_D is found which can then be used to construct a velocity profile or *intrinsic velocity spectrum* (IVS). The sample rate was 500 kS/s and so the values of dt must all be integer multiples of $2 \mu\text{s}$. Inspection of the biologically plausible range of velocities ($0 \text{ m s}^{-1} - 100 \text{ m s}^{-1}$) showed the main populations to be in the range of $5 \text{ m s}^{-1} - 20 \text{ m s}^{-1}$. The sampling rate used is considerably higher than in previous work and so there is no requirement to interpolate the data [6]. It should be noted that the relationship between the delay size dt and the velocity is not linear and so there is greater resolution at lower velocities [9]. Note that it is possible to use negative values of dt which provides a method to examine negative velocities. During recordings it is therefore possible to extend this method to detect and analyse action potentials which are propagating in both directions along the nerve.

III. RESULTS

A. Surgical Issues

Initially a larger electrode array was trialled with an electrode spacing of 3 mm and utilising thicker tungsten wire (0.5 mm). Larger electrode spacing should provide improved selectivity as the delay dt required becomes much larger than the sampling interval. However the electrodes were found to be very inflexible and difficult to produce with uniform shapes. It was difficult to lift a large enough section of nerve into the hooks without accidentally damaging the nerve. Also, once the nerve was located in the hooks it proved challenging to establish a reliable contact between the nerve and the surface of each electrode. The inflexible geometry of the electrodes and the relative rigidity of the nerve (due to stretching tension) prevented the nerve from sitting satisfactorily on all of the electrodes.

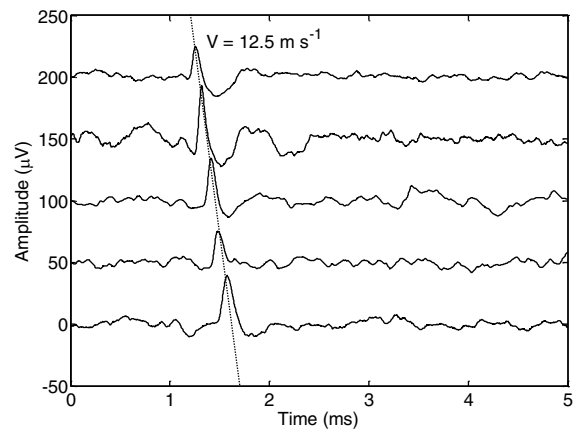

Figure 2: Recorded action potential after bipolar amplification showing propagation in time. The dashed line indicates a propagation time corresponding to a velocity of 12.5 m s^{-1} .

The smaller electrode array described previously provided significantly more success. The electrode spacing of 1 mm produced a much shorter array (5 mm) reducing both the surgical and mechanical constraints on locating the nerve in the hooks. Each hook was flexible and so the weight of the nerve naturally aligned each hook to follow the contour of the nerve, resulting in a reliable physical contact between the two.

B. Data Analysis

Recordings were made during periods of stimulation (both cutaneous and electrical) and during a resting period where no direct stimulation was applied to the animal. A single action potential as recorded during a resting phase (Fig. 2) was chosen for analysis of the system characteristics. The input-referred noise floor was measured using a period of no activity and ranged from $4.04 \mu\text{V}_{\text{rms}}$ to $7.31 \mu\text{V}_{\text{rms}}$ per channel, the peak to peak signal values were in the range of $33.34 \mu\text{V}_{\text{pp}}$ to $65.49 \mu\text{V}_{\text{pp}}$. The velocity of the single action potential (Fig. 2) was estimated manually by measuring the relative delay from peak-to-peak over each channel. The inter-channel delay ranged from $62 \mu\text{s}$ to $96 \mu\text{s}$ with an average delay value of $80 \mu\text{s}$ and the inter-electrode distance was 1 mm, therefore the velocity of this action potential was approximately 12.5 m s^{-1} (2).

$$V = \frac{d}{t} = \frac{1 \times 10^{-3}}{80 \times 10^{-6}} = 12.5 \text{ m s}^{-1} \quad (2)$$

The variation in inter-channel delay can be explained by the non-uniform spacing of the hook electrodes which deform slightly under the weight of the nerve. The delay-and-add procedure essentially averages this variation and the effect is negated for larger numbers of electrodes. The IVS of the action potential (Fig. 3) was generated using the delay-and-add procedure which computes responses for fixed delay values, thus any variance from channel to channel appears as a spreading in the velocity domain. The action potential has a finite bandwidth (in the frequency domain) and this also produces a spreading in the velocity domain, reducing the ability of the system to discriminate one velocity from another. We quantify this spreading using the velocity quality factor, Q_v , which is given by [2] (3).

$$Q_v = \frac{v_0}{v_{3+} - v_{3-}} \quad (3)$$

Where v_0 is the peak velocity and v_{3+} and v_{3-} are the velocities at which the summed output has dropped to -3dB of the peak value. For the single action potential (Fig. 3) the quality factor was 1.48. Various methods exist to improve the velocity selectivity; such as the use of band pass filters [3] and neural networks [10].

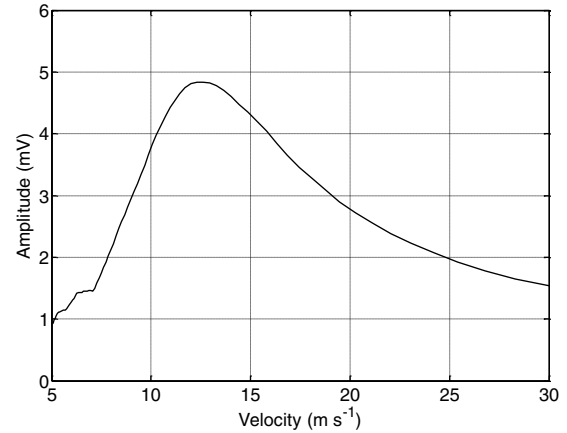

Figure 3: Intrinsic Velocity Spectrum calculated for a single action potential using the delay-and-add process. The peak velocity is $\sim 12.5 \text{ m s}^{-1}$ with a quality factor of 1.48.

C. Electrical & Cutaneous Stimulation

Both electrical and cutaneous stimulation was applied to the L5 dermatome in an attempt to elicit a response within the fascicle. Firstly a 1 mA square wave pulse was applied using a single wire electrode. The IVS was computed from a 5 ms recording taken directly after the application of the stimulus pulse (Fig. 4), showing a high level of activity centred on 10.2 m s^{-1} with a quality factor of 1.22.

Two full length recordings (250 ms) were made sequentially with and without manual cutaneous stimulation applied to the skin. The velocity spectra of the two recordings (Fig. 5) clearly show the presence of a number of dominant velocity populations. The resting spectrum features two distinctive peaks at 10 m s^{-1} and 13 m s^{-1} respectively with similar maximum amplitudes. During cutaneous stimulation there is a large increase in the maximum amplitude at a velocity of 10 m s^{-1} , which is in agreement with the changes observed during electrical stimulation of the L5 dermatome. Activity at 13 m s^{-1} has decreased and a new peak is visible at 16 m s^{-1} .

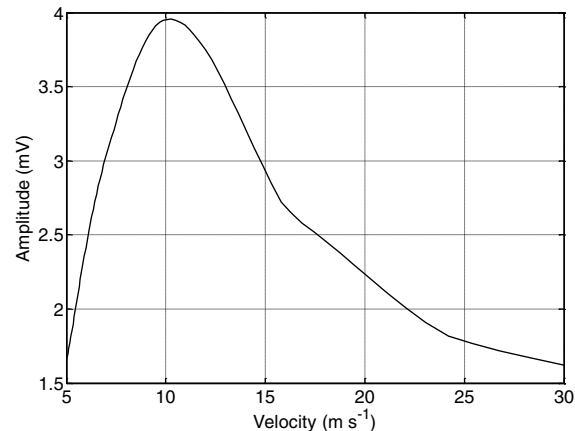

Figure 4: Intrinsic velocity spectrum for 5ms of electrically evoked recording with a distinct peak at 10.2 m s^{-1} and a Q_v value of 1.22.

IV. DISCUSSION

We obtained velocity profiles from both electrically evoked and physiological action potentials within *rat*. The intrinsic velocity selectivity was constrained by the space available to locate the recording electrodes. Various different electrode geometries were evaluated in an attempt to maximise the quality and effectiveness of the recordings.

Distinct action potentials were recorded along each electrode array although there was some variation in amplitude. Two possible explanations for this latter effect are (i) subtle variations in the amplifier gains (from one channel to another) or, (ii) the possible variation in external resistance along the length of the fascicle which can affect the amplitude of recorded signals [11]. Unlike in the case of cuff electrodes the position of the nerve within the hooks is not constrained and so it is likely that the electrode contact impedance was not completely consistent from one contact point to another.

No further filtering or averaging was required as the signal-to-noise ratio of the data was already very high. There was no observable common mode interference and so the use of a *tripolar* configuration (which reduces common mode interference [11]) was not warranted. In addition, the availability of high speed data acquisition hardware meant there was no requirement to interpolate the data.

We were able to observe noticeable changes in the velocity spectra of recordings made from the same nerve when either electrical or cutaneous stimulation was applied and the changes were consistent from one recording to another. As the delay-and-add process only takes the maximum value over the entire time recording there is no temporal information extracted. This approach is well suited to the study of electrically evoked CAPs where there is inherent time synchronisation but it does not extend well to the analysis of naturally occurring neural signals where action potentials of different velocities are generated randomly and key data is encoded in the firing rate.

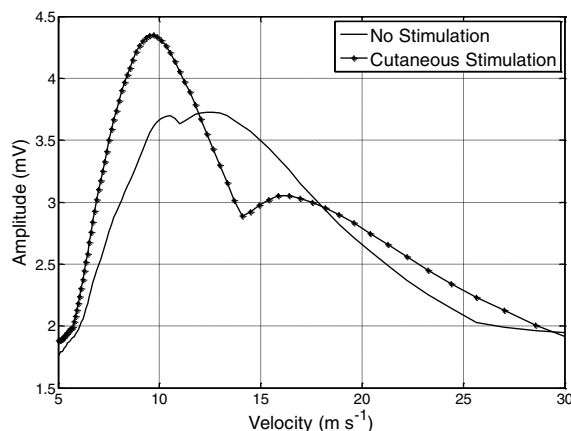

Figure 5: Intrinsic velocity spectrum for 250 ms long recordings. The dotted line indicates cutaneous stimulation was applied, the solid line indicates no stimulation was applied.

V. CONCLUSION

The method of VSR was applied to naturally occurring neural signals of a *rat in-vivo*. The physiological recordings had much lower amplitudes than electrically evoked CAPs. Velocity profiles were obtained for background activity as well as for manual and electrical stimulation of the L5 dermatome. It was possible to identify periods of stimulation based on changes within the velocity spectra. The method was able to identify physiological nerve activity but did not produce any measure of the firing rate for particular neurons, which is of interest for advanced neural prostheses. A method for extracting neuronal firing rates using VSR has been proposed by the authors [12].

VI. ACKNOWLEDGMENTS

This work was generously supported by the Brian Nicholson PhD scholarship.

VII. REFERENCES

- [1] H. Gasser, "The classification of nerve fibers.," *Ohio J. Sci.*, vol. 41, no. 3, pp. 145–159, 1941.
- [2] N. Donaldson, R. Rieger, M. Schuettler, and J. Taylor, "Noise and selectivity of velocity-selective multi-electrode nerve cuffs.," *Med. Biol. Eng. Comput.*, vol. 46, no. 10, pp. 1005–18, Oct. 2008.
- [3] J. Taylor, M. Schuettler, C. Clarke, and N. Donaldson, "A summary of the theory of velocity selective neural recording.," *Conf. Proc. IEEE Eng. Med. Biol. Soc.*, vol. 2011, pp. 4649–52, Jan. 2011.
- [4] C. T. Clarke, X. Xu, R. Rieger, J. Taylor, and N. Donaldson, "An implanted system for multi-site nerve cuff-based ENG recording using velocity selectivity.," *Analog Integr. Circuits Signal Process.*, vol. 58, no. 2, pp. 91–104, Nov. 2008.
- [5] G. Schalow, G. Zäch, and R. Warzok, "Classification of human peripheral nerve fibre groups by conduction velocity and nerve fibre diameter is preserved following spinal cord lesion.," *J. Auton. Nerv. Syst.*, vol. 1838, no. 6, 1995.
- [6] M. Schuettler, V. Seetohul, N. J. M. Rijkhoff, F. V. Moeller, N. Donaldson, and J. Taylor, "Fibre-selective recording from peripheral nerves using a multiple-contact cuff: Report on pilot pig experiments.," *Conf. Proc. IEEE Eng. Med. Biol. Soc.*, vol. 2011, pp. 3103–6, Aug. 2011.
- [7] M. Schuettler, V. Seetohul, J. Taylor, and N. Donaldson, "Velocity-selective recording from frog nerve using a multi-contact cuff electrode.," *Conf. Proc. IEEE Eng. Med. Biol. Soc.*, vol. 1, pp. 2962–5, Jan. 2006.
- [8] D. J. Chew, L. Zhu, E. Delivopoulos, I. R. Minev, K. M. Musick, C. a Mosse, M. Craggs, N. Donaldson, S. P. Lacour, S. B. McMahon, and J. W. Fawcett, "A microchannel neuroprosthesis for bladder control after spinal cord injury in rat.," *Sci. Transl. Med.*, vol. 5, p. 210ra155, 2013.
- [9] J. Taylor, M. Schuettler, C. Clarke, and N. Donaldson, "The theory of velocity selective neural recording: a study based on simulation.," *Med. Biol. Eng. Comput.*, vol. 50, no. 3, pp. 309–18, Mar. 2012.
- [10] A. Al-Shuelli, C. Clarke, N. Donaldson, and J. Taylor, "Improved Signal Processing Methods for Velocity Selective Neural Recording Using Multi-Electrode Cuffs.," *IEEE Trans. Biomed. Circuits Syst.*, pp. 1–11, Sep. 2013.
- [11] M. Rahal and J. Winter, "An improved configuration for the reduction of EMG in electrode cuff recordings: a theoretical approach.," *IEEE Trans. Biomed. Eng.*, vol. 47, no. 9, pp. 1281–1284, 2000.
- [12] B. W. Metcalfe, D. J. Chew, C. T. Clarke, N. Donaldson and J. Taylor, "An Enhancement to Velocity Selective Discrimination of Neural Recordings: Extraction of Neuronal Firing Rates," *Conf. Proc. IEEE Eng. Med. Biol. Soc.* 2014.