

# Development and initial testing of a prototype concentric tube robot for surgical interventions

Costas Sophocleous\*, Eftychios G. Christoforou<sup>†</sup>, Panayiotis S. Shiakolas<sup>‡</sup>,  
Ioannis Seimenis<sup>§</sup>, Nikolaos V. Tsekos<sup>¶</sup> and Charalambos C. Douranidis\*

\*Dept. of Mechanical and Manufacturing Engineering, University of Cyprus, Nicosia, Cyprus

<sup>†</sup>KIOS Research Center, University of Cyprus, 75 Kallipoleos Avenue, 1687 Nicosia, Cyprus

Email: e.christoforou@ucy.ac.cy (Corresponding Author)

<sup>‡</sup>Mechanical and Aerospace Engineering, The University of Texas at Arlington, Arlington, TX, USA

<sup>§</sup>Dept. of Medicine, Democritus University of Thrace, Alexandroupolis, Greece

<sup>¶</sup>Dept. of Computer Science, University of Houston, Houston, TX, USA

**Abstract**—The development and initial testing of a prototype concentric tube robot suitable for surgical applications is presented. The system is endowed with 3 degrees-of-freedom and consists of a three concentric tubes assembly and an actuation module. Design issues are discussed in a general context of concentric tube robots in view of their potential applications in surgery. Among the distinct features of the system is that the actuation module provides a mechanical decoupling between the available motions that effectively facilitates control of the device. Such robotic systems are considered particularly suitable for MR-guided interventions and compatibility issues with the specific imaging modality are discussed. Initial experimental testing of the device is presented which involved tip targeting and steering trials using direct visual feedback for guidance.

**Index Terms**—Concentric tube robots, medical robotics, image-guided interventions

## I. INTRODUCTION

A continuum robot constitutes a special type of manipulator capable of adjusting its continuously curving members in order to perform tasks requiring end-effector positioning/path-following and whole-arm grasping/manipulation of objects. A related class of robotic systems are the snake-like robots that were considered both for manipulation and locomotion purposes (e.g., [1], [2]) but this is outside the scope of the present work. Continuum robots belong to a class of biologically-inspired systems resembling the structure/function of snakes, elephant trunks, octopus tentacles, etc. In general, such robots can enter spaces through small openings, exhibit remarkable maneuverability inside confined spaces, can follow curved pathways and perform highly dexterous tasks. Continuum robots have become an emerging field in robotics with various potential applications including surgery at the epicenter.

Continuum systems theoretically possess an infinite number of degrees-of-freedom (DOF) and can assume rather complicated shapes. A classification of the most common types of continuum robots based on their motion system realization was provided by [3]: (1) Robots shaped by continuously bending actuators (e.g., [4]), (2) Robots shaped by tendons (e.g., [5], [6], [7]), (3) Concentric tube robots (e.g., [8], [9], [10]), and (4) Steerable needles (e.g., [11]). Other types of continuum robots were also proposed including the pneumatically actuated sys-

tem of [12]. The present work focuses on the third class of the abovementioned systems, namely concentric tube robots. They consist of a concentric tubes assembly, with member tubes allowed to telescopically extend/rotate relevant to each other along/about their common axis. Selected members are precurved so that upon extension they assume a curved shape, while releasing their stored elastic energy. At the inboard end of the robot is located the actuation device and at the distal end can be attached an application-specific end-effector (e.g., forceps, scissors, cameras).

Compared to other continuum robot implementations (e.g., involving tendons), concentric tube robots are inherently compact and can be constructed in small diameters. This makes them particularly suitable for operating inside confined spaces and also allows for miniaturization as required for micromanipulation tasks. A convenient feature of concentric tube robots is that the innermost tube may provide an unobstructed passage through which actuation elements (e.g., strings, electric cables, pressurized liquid, etc.) can reach the end-effector situated at the distal end of the continuum system.

Concentric tube robots differ from articulated robots in terms of kinematics/dynamics analysis and control. In fact, links and joints of a concentric tube robot are part of the same entity. Various mechanics models regarding concentric tube systems have already been developed [8], [9], [10]. A recent review paper on kinematics modeling of constant curvature continuum robots was provided by [3]. The kinematics foundation of continuum robots is outside the scope of this paper, which maintains a focus on mechanical design aspects. In particular, a 3-DOF concentric tube robot is presented featuring a novel actuation mechanism. The prototype system was constructed and initial experimental testing on tip targeting and steering was carried out. The purpose of the prototype is to serve as a testbed for validating relevant mechanics models and examine the potential of concentric tube robots in surgical applications.

## II. MEDICAL APPLICATIONS

A fertile field of applications for concentric tube robots exists in the surgical interventions domain; thus they are

commonly referred to as “active cannula systems”. In particular, potential for using concentric tube robots exists in two surgical paradigms: (1) Minimally-invasive surgery (MIS) which is carried out through small incisions on the body (e.g., abdominal wall) providing percutaneous access for the surgical instruments. Among the advantages of MIS are included the reduced trauma to the body, less risk of infection, faster recovery and minimal scarring. Special robotic technology has already been developed for this type of interventions [13]. In cases where the number of incisions is reduced to one the procedure is referred to as single port access (SPA) surgery and can be facilitated by specially-designed continuum robot systems [14]. (2) Natural orifice transluminal endoscopic surgery (NOTES) uses natural body orifices (e.g., mouth, nostrils, vagina, urethra, rectum) in order to provide surgical instruments with an entry point to access internal organs (e.g., stomach, bladder) and perform, for example, a transvaginal cholecystectomy [15]. For this reason NOTES is often referred to as “scarless surgery”.

Concentric tube robots, as well as continuum robots in general, are expected to have a most significant impact in two specific surgical areas: cardiac surgery and neurosurgery. Their usage is expected to eventually allow for complex intracardial repairs to be carried out on a beating heart (e.g., mitral valve annuloplasty). This will allow avoiding the risk for complications associated with temporarily stopping the heart while performing the surgery. In such case the establishment of a biomotion compensation scheme will be required so that the manipulation system tracks the cardiac motion and prevents collisions with sensitive internal cardiac structures. A one-DOF robotic catheter system developed for this purpose [16], [17] is capable of performing tip motions while tracking the tissue motion under ultrasound-based servoing. A multi-DOF concentric tubes system is expected to meet this requirement even more effectively. Regarding neurosurgery, continuum robots operating inside the cerebrospinal fluid spaces are expected to facilitate various procedures, as for example the coagulation of the choroid plexus that was considered in [18]. Therein, an approach is proposed for the optimal design of a concentric tube robot intended for neurosurgical applications.

### III. PROTOTYPE SYSTEM DESIGN

In a surgical scenario the envisaged use of the device includes an initial manual deployment of the continuum system (through a hole or a natural orifice) until it reaches the surgical site (macro-positioning). The next stage will involve fine controlled motions at the tip level (micro-positioning) for performing the required tasks under some form of image guidance (e.g., ultrasound guidance). The robotic hardware itself is composed of two distinct parts that were individually considered as part of the design work: (1) The concentric tubes assembly, that constitutes the continuum system, at the distal end of which can be installed an application-specific tool (end-effector), (2) The actuation module which is located at the base of the system and produces the required controlled motions of the tubes. Design specifications included the appro-

priateness of the kinematics structure and the adequacy of DOF in order to allow performing tip positioning and steering tasks, a mechanical structure that minimizes unwanted transmission effects (friction, backlash, elasticity) and facilitates control, as well as compactness and portability of the device so that it can be effectively accommodated in a surgical setup. The device was designed as a general-purpose system, i.e., it is not application- or anatomy-specific.

#### A. MR-compatibility requirements

Given that the intended use of the device will require image guidance a basic design requirement has also been the compatibility with the imaging modalities that the robot will be used in conjunction with. Possible candidates include X-rays, computed tomography (CT), ultrasound (US) and magnetic resonance imaging (MRI). Using MR-guidance is highly desirable given that it capitalizes on images of unsurpassed quality, may exploit its 3-dimensional imaging capabilities and the option to adjust the imaging plane, as well as other imaging parameters, in real time [19]. Moreover, the operation of the specific imaging device does not involve any potentially harmful ionizing radiation (as in the case of X-rays and CT) and therefore, it is considered to be relatively safe for the patient as well as for the operating physician. However, an impediment to the real-time MR guidance of interventions has been the limited accessibility to the patient inside the scanner, which can be realized through robotic assistance [20]. A concentric tube robot being a compact system can effectively address the imposed geometric constraints [21]. Another remaining obstacle is due to the magnetic nature of the modality. In fact, the MRI scanner imposes strict limitations to any object exposed to its environment which has to be MR-safe and MR-compatible [22]. MR-compatible robotic systems in specific are required to have appropriate construction materials, sensors and actuators [20]. The developed system was designed with the prospect of using it under MR-guidance following some modifications to the initial prototype. Various scanner types exist but the main interest focuses on closed-cylindrical scanners which have high static magnetic fields (1.5-3.0 Tesla) and provide better quality images compared to open scanners. Further MR-compatibility issues will be discussed in the sequel.

#### B. Concentric tubes system and degrees-of-freedom

Defining the required kinematics structure of a concentric tube robot involves deciding about the number of tubes, specifying which individual tubes will be precurved and the required motions for each tube member (translation, rotation or both). The actuation device is then designed accordingly in order to realize the controlled motions. Critical for an efficient telescopic and rotational motion of the tubes is to assign appropriate dimensional tolerances to the individual tube diameters in order to eliminate mechanical play (backlash), avoid high friction, and minimize torsional flexibility, which are effects imposing performance limitations to the controlled behaviour. Friction is difficult to model and increases while the continuum

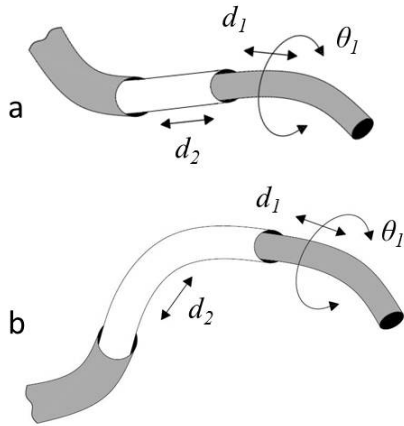

Fig. 1. (a) The three-tube configuration of the prototype continuum system and the corresponding motions. The innermost tube is allowed both extension and rotation ( $d_1, \theta_1$ ), whereas the intermediate tube is only allowed telescopic extension ( $d_2$ ). Only the innermost tube is precurved. (b) The above three-tube configuration is implemented here with both the intermediate and innermost tubes precurved. Both configurations can use the same actuation unit.

system curves. It causes positioning errors and combined with flexibility may result to jerky motions of the moving tubes. Critical for the reduction of friction is the appropriate selection of materials for the tube members as well as lubrication. Another key design issue is how the bending stiffness values should be allocated to the individual component tubes, which will affect the resultant overall shape of the continuum system. In general, every tube should be more stiff than any precurved tubes that it embraces. Telescopic sections which are precurved, upon extension they assume a curved shape. However, when retracted they should conform to the shape of the outer (stiffer) tubes without considerably affecting their curvature.

Design tradeoffs are involved when defining the DOF and the kinematics structure of the continuum robot. Practically, a concentric tubes system with many DOFs may effectively use its motions to accurately position its tip while operating in open spaces. Otherwise, physical contacts render basic model predictions regarding the tip positions obsolete. Given that the number of DOF corresponds to the number of concentric tubes involved, the more DOF the more thick the continuum system will result. Also, kinematic redundancy needs to be managed through motion planning and active control adding complexity to the relevant algorithms. The developed system is endowed with 3 DOF as depicted in Figure 1a and involves the combination of three tubes. The outside tube is used for the initial manual overall positioning of the system. At the tip of the continuum system the base prismatic joint contributes a pure rectilinear motion (1 DOF). The second (distal) joint combines an extension and rotation of the precurved member (2 DOF). These motions are in fact rather intuitive for an operator to manage efficiently. Using the actuation device that was developed the same motions can also be implemented on a 3-tube system with both the middle and the outer tube

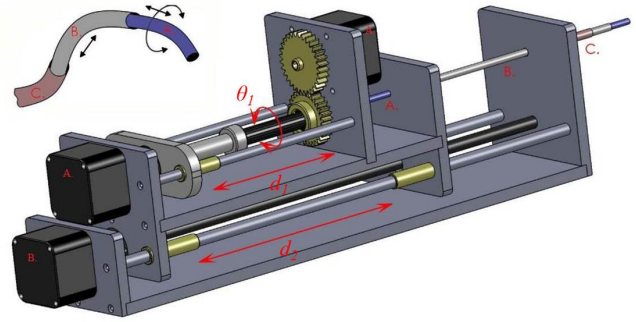

Fig. 2. Solid model representing the prototype system design. The arrows show the available motions of the actuation module ( $\theta_1, d_1, d_2$ ) and the correspondence to the motions of the continuum concentric tubes system.

members precurved, as shown in Figure 1b.

From a surgical perspective the concentric tubes assembly is required to be easily detachable from the actuation module and that is how it was implemented with the current design. This will facilitate an initial free-hand positioning of the continuum system before connecting it to the actuation device in order to proceed with the computer-controlled mode. It also allows for the continuum system to be disposable or removable for sterilization purposes (note that the actuation module itself can be fully inserted in a sterile bag if required). Regarding the overall length of the active cannula system this will be dictated by application requirements (e.g., the target's depth). However, maintaining a minimum length helps minimize friction. In the case of MR-guided interventions the tubes' length should also allow for the system to reach and operate inside the scanner at the vicinity of the isocenter. In that area the main magnetic field is more homogenous yielding images of better quality and with minimal spatial distortions.

### C. The actuation module

The importance of controlling a concentric tube robot through a computer-controlled actuation device becomes apparent if we consider the kinematics complexity of an assembly with many DOF. The kinematics position solutions are rendered less intuitive to be mentally handled by the operator while manually operating the end-effector. Motion planning algorithms incorporating kinematics models are expected to enhance the capabilities of the system. Also, in cases where the system needs to automatically position itself as part of a biomotion compensation scheme (e.g., position adjustments in response to respiratory or cardiac motions) corrections can only be handled effectively by an automated system. Compared to manual actuation the use of a robotic device presents further favorable features including precision, steady-hand characteristics, force and motion scaling, etc.

The actuation module was designed as a generic system for driving any three-tube continuum robot with the aforementioned DOF (shown in Figure 1). The concentric tubes

TABLE I  
LIMITS FOR THE INDIVIDUAL MOTIONS OF THE ACTUATION MODULE.

Motion variable	Travel limits
$d_1$	$\pm 4$ cm
$d_2$	$\pm 6$ cm
$\theta_1$	$\pm 180^\circ$

connect to the actuation device and appropriately engage with the motion system. The DOF of the actuation device are shown in Figure 2, which also depicts the direct correspondence to the motions of the concentric tubes system. The motion system incorporates two stacked translational stages corresponding to each one of the two telescopic motions ( $d_1$ ,  $d_2$ ). In particular, the bottom stage corresponds to the intermediate tube and the top stage to the innermost tube. This arrangement constitutes the two translational motions independent. Each one of the two stages is mounted on and slides along a parallel rails system. The two stages are actuated via electric motors and a lead-screw mechanism is used to convert the rotational motion of the motors to translational with a fixed transmission ratio (lead=20 mm). A third motor is responsible for rotating the innermost tube ( $\theta_1$ ). This rotation involves a spur gears pair (transmission ratio = 1), which rotates a splined shaft passing through the output gear, while transmitting its rotation to the innermost tube. This arrangement effectively realizes a mechanical decoupling between the translation/rotation motions of the innermost tube. It also allows for the two motions to be controlled independently, which is advantageous in terms of control.

#### D. System actuation and control

Stepper motors were used for the actuation of the prototype system, which allow for accurate open-loop position control. Given the system's modular design these motors can be readily replaced with different type motors (e.g., DC servo motors). For using the device under MR conditions an appropriate choice for actuation would be piezoelectric motors. Their operation does not involve magnetic field interactions with the scanner, as long as they are kept outside the scanner at a sufficient distance from the imaging volume. Concentric tube robots are inherently remotely-actuated devices, which is consistent with the aforementioned requirement. Remote actuation has been used with other articulated MR-compatible robotic systems, as for example a 5-DOF general-purpose robotic system that uses piezoelectric actuators [23], [24].

#### IV. PROTOTYPE SYSTEM AND INITIAL TESTING

The prototype system is shown in Figure 3 with a plastic transparent enclosure installed over the moving parts of the actuation module. The main construction material for the actuation module has been aluminum. Certain small-sized parts were constructed of bronze as well as stainless-steel. Plastic tubes were used to construct the continuum system and lubrication helped minimize friction between them. The size of the actuation device is 57(length) $\times$ 13.5(width) $\times$ 19(height)

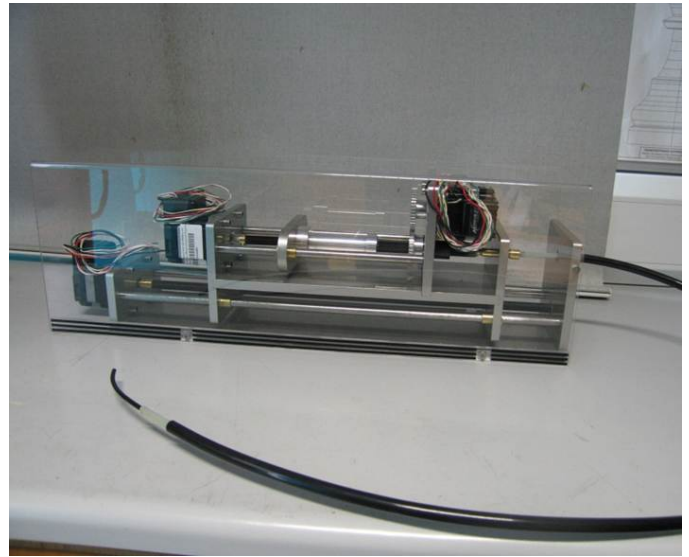

Fig. 3. The developed prototype system. It includes the actuation module and the continuum system that consists of three concentric tubes.

cm. The overall length of the continuum system is 75 cm when all tubes are fully retracted. The tubes that were used have outside diameters of 10, 6, and 4 mm, respectively. The travel limits for each individual motion are collected in Table I. The continuum system is interchangeable and can be quickly affixed to the motion platform during an intervention, without requiring any special tools or a specialized technician for this purpose. This facilitates the initial manual positioning of the device before proceeding with computer control. With the current version of the device the actuators are independently controlled by the operator directly from the control computer. Limit switches were installed on the device to restrict the travel of each individual motion.

Initial experimental testing of the device focused on the ability of the system to acquire a target using direct visual feedback and evaluate the efficiency of its kinematic structure for performing tip steering tasks. Benchtop testing was carried out with the operator manually controlling the available motions through the computer. Two different tests were carried out. The setup for the first test involved a transparent box representing a cavity into which the active cannula system can be manually inserted (Figure 4(a)) through a hole (10 mm in diameter) before directing its tip towards a target, as in the case of a MIS. The dimensions of the box were 31(length) $\times$ 23(width) $\times$ 19(height) cm. Figure 4(b-f) shows a sequence of motions starting with the initial manual deployment of the continuum system through an entry hole, followed by the computer-controlled stepwise motions at the tip level to acquire the target. The target was a coin (19.5 mm in diameter) affixed on a side wall. Each photo corresponds to a single motion-axis step. The same experiment was successfully repeated for different positions of the target on the box's walls.

The second test carried out involved a curved transpar-



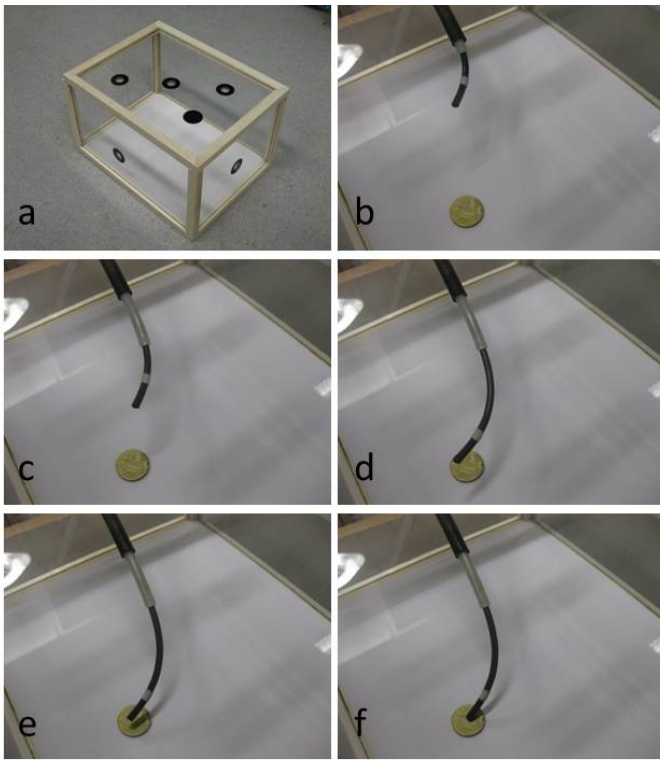

Fig. 4. (a) Experimental setup used for evaluating the ability of the system to operate inside body cavities and acquire targets as required in minimally-invasive surgery (MIS) applications. (b)-(f) Motion sequence showing the initial manual deployment of the system followed by acquisition of a target while performing stepwise motions under direct visual feedback.

ent plastic tube of 2 cm internal diameter. The continuum robot was initially manually inserted in the tube with the tip approaching a side hole (15 mm in diameter), as shown in Figure 5a. Then by controlling the device through the computer and using direct visual feedback the tip advances towards the hole and passes through it. The corresponding sequence of motions is shown in Figure 5(b-h). Again, each photo corresponds to a single motion-axis step. This scenario is analogous to a steering task during a NOTES intervention.

While performing the above tests the assigned DOF were found highly effective for target acquisitions inside the cavity's volume as well as steering the tip in order to direct the continuum system towards a new path. The rather intuitive kinematics structure of the robotic device allowed the operator to comfortably operate the system by controlling each motion independently through the computer after minimal training.

## V. DISCUSSION

A distinct feature of the developed robotic system is its computer-controlled actuation module. Even though it is limited to controlling a 3-DOF concentric tubes system all the available motions can be independently controlled. This effectively facilitates the control of the system. A different actuation device for active cannula robots was developed in one of the key works in the field by Webster [25]. In that case,

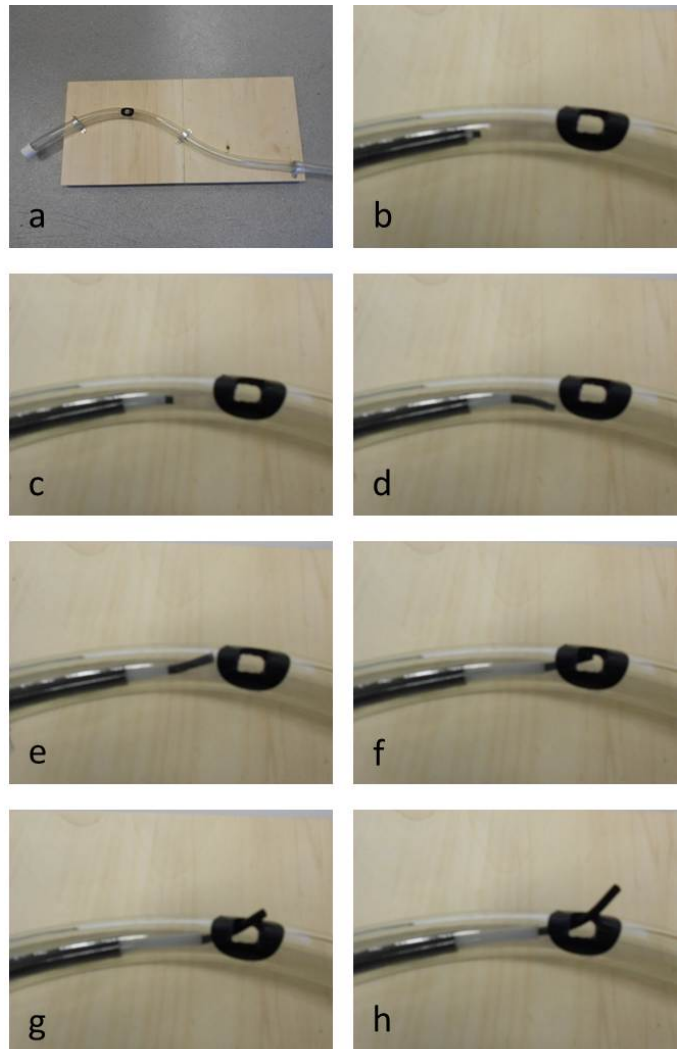

Fig. 5. (a) Experimental setup used for evaluating the ability of the system to pass through a curved passage and then redirect its tip to go through a hole, as required in natural orifice transluminal endoscopic surgery (NOTES) applications. (b)-(h) Motion sequence showing the initial manual deployment of the system followed by stepwise motion of the tip in order to approach and then go through a side hole.

the basic actuation unit has the ability to translate and rotate a single tube of the system, while other tubes are allowed to pass through it. The two available motions are not independent due to mechanical coupling that exists. Consequently, for a pure rotation of the tube a simultaneous translational adjustment is required in compensation for an induced axial motion. A useful feature of that specific device is that a multi-DOF active cannula system can be actuated using a train of the aforementioned basic actuation modules arranged in series.

Various other actuation systems were developed and employed for the experimental verification of theoretical kinematics models of concentric tube systems. A manual actuation unit based on a two-tube configuration was used in [9]. Also, in [10] a manually actuated device includes input handles which are etched to encode rotation. The support structure is also

etched with a ruler that encodes translation. An experimental actuation setup was used for testing kinematics models based on a three concentric tubes arrangement in [8]. A 6-DOF MR-compatible concentric tubes robotic system was presented in [26], which is actuated using piezoelectric motors. In fact, the system was adapted from a previously developed robot dedicated to prostatic biopsies under MR-guidance. A continuum system was added to the Cartesian stage of the basic original system. The three-tube continuum system used was structured to provide a rotation and translation of the middle precurved tube, as well as translation of the innermost one. This specific kinematics structure is similar but different from the one proposed and implemented herein.

Testing of the developed device was carried out using direct visual feedback. The next step will be to implement image guidance using an appropriate imaging modality. Particular interest exists in using the device under MR-guidance. The continuum system consists of plastic tubes which are perfectly MR-compatible. The main construction material for the actuation module was aluminum, which in general is MR-safe. However, aluminum is conductive and parts constructed of this material are required to remain outside the gantry to prevent related image artifacts. Further work needs to focus on the MR-compatibility characteristics of the device. As part of the required modifications it will also be considered replacing its actuators with piezoelectric motors. The compatibility characteristics of the device remain to be thoroughly tested before proceeding with actual experiments on image guidance. Future work will also focus on image-based preoperative motion planning and the development of software tools/user interfaces to facilitate this process, as for example in [27]. Motion planning algorithms should incorporate analytical mechanics models and for this purpose both the forward and inverse kinematics solutions become relevant. The effective combination of the device and the imaging modality is expected to further enhance the capabilities of the operating physician in performing standard as well as novel surgical applications.

#### REFERENCES

- [1] A. A. Transeth, K. Y. Pettersen, and P. Liljebäck, "A survey on snake robot modeling and locomotion," *Robotica*, vol. 27, no. 7, pp. 999–1015, 2009.
- [2] J. K. Hopkins, B. W. Spranklin, and S. K. Gupta, "A survey of snake-inspired robot designs," *Bioinspiration & Biomimetics*, vol. 4, no. 2, pp. 1–19, 2009.
- [3] R. J. Webster and B. A. Jones, "Design and kinematic modeling of constant curvature continuum robots: a review," *Int. J. Robotics Research*, vol. 29, no. 13, pp. 1661–1683, 2010.
- [4] E. Ayvali, C.-P. Liang, M. Ho, Y. Chen, and J. P. Desai, "Towards a discretely actuated steerable cannula for diagnostic and therapeutic procedures," *Int. J. Robotics Research*, vol. 31, no. 5, pp. 588–603, 2012.
- [5] D. B. Camarillo, C. F. Milne, C. R. Carlson, M. R. Zinn, and J. K. Salisbury, "Mechanics modeling of tendon-driven continuum manipulators," *IEEE Trans. on Robotics*, vol. 24, no. 6, pp. 1262–1273, 2008.
- [6] R. S. Penning, J. Jung, J. A. Borgstadt, N. J. Ferrier, and M. R. Zinn, "Towards closed loop control of a continuum robotic manipulator for medical applications," in *Proc. of IEEE Int. Conference on Robotics & Automation*, Shanghai, China, May 9–13 2011, pp. 4822–4827.
- [7] R. Cieslak and A. Morecki, "Elephant trunk type elastic manipulator - a tool for bulk and liquid materials transportation," *Robotica*, vol. 17, no. 1, pp. 11–16, 1999.
- [8] P. E. Dupont, J. Lock, B. Itkowitz, and E. Butler, "Design and control of concentric-tube robots," *IEEE Trans. on Robotics*, vol. 26, no. 2, pp. 209–225, 2010.
- [9] D. C. Rucker, B. A. Jones, and R. J. Webster, "A geometrically exact model for externally loaded concentric-tube continuum robots," *IEEE Trans. on Robotics*, vol. 26, no. 5, pp. 769–780, 2010.
- [10] D. C. Rucker, R. J. Webster, G. S. Chirikjian, and N. J. Cowan, "Equilibrium conformations of concentric-tube continuum robots," *Int. J. Robotics Research*, vol. 29, no. 10, pp. 1263–1280, 2010.
- [11] R. Alterovitz, K. Goldberg, and A. Okamura, "Planning for steerable bevel-tip needle insertion through 2D soft tissue with obstacles," in *Proc. of IEEE Int. Conference on Robotics & Automation*, Barcelona, Spain, April 18–22 2005, pp. 1640–1645.
- [12] M. B. Pritts and C. D. Rahn, "Design of an artificial muscle continuum robot," in *Proc. of IEEE Int. Conference on Robotics & Automation*, New Orleans, LA, April 26 - May 1 2004, pp. 4742–4746.
- [13] C.-H. Kuo, J. S. Dai, and P. Dasgupta, "Kinematic design considerations for minimally invasive surgical robots: an overview," *Int J Med Robotics Comput Assist Surg*, vol. 8, no. 2, pp. 127–145, 2012.
- [14] K. Xu, R. E. Goldman, J. Ding, P. K. Allen, D. L. Fowler, and N. Simaan, "System design of an insertable robotic effector platform for single port access (SPA) surgery," in *Proc. of IEEE/RJS Int. Conf. on Intelligent Robots and Systems*, St. Louis, MO, October 11–15 2009, pp. 5546–5552.
- [15] J. Noguera, C. Dolz, A. Cuadrado, J. Olea, A. Vilella, and R. Morales, "Hybrid transvaginal cholecystectomy, NOTES, and minilaparoscopy: analysis of a prospective clinical series," *Surgical Endoscopy*, vol. 23, no. 4, pp. 876–881, 2009.
- [16] S. B. Kesner, S. G. Yuen, and R. D. Howe, "Ultrasound servoing of catheters for beating heart valve repair," in *Information processing in computer-assisted interventions*, N. Navab and P. Jannin, Eds. Springer, 2010.
- [17] S. B. Kesner and R. D. Howe, "Force control of flexible catheter robots for beating heart surgery," in *Proc. of IEEE Int. Conference on Robotics & Automation*, Shanghai, China, May 9–13 2011, pp. 1589–1594.
- [18] T. Anor, J. R. Madsen, and P. Dupont, "Algorithms for design of continuum robots using the concentric tubes approach: a neurosurgical example," in *Proc. of IEEE Int. Conference on Robotics & Automation*, Shanghai, China, May 9–13 2011, pp. 667–673.
- [19] E. Christoforou, E. Akbudak, A. Ozcan, M. Karanikolas, and N. V. Tsekos, "Performance of interventions with manipulator-driven real-time MR-guidance: Implementation and initial in vitro tests," *Magnetic Resonance Imaging*, vol. 25, no. 1, pp. 69–77, 2007.
- [20] N. V. Tsekos, A. Khanicheh, E. Christoforou, and C. Mavroidis, "Magnetic resonance-compatible robotic and mechatronics systems for image-guided interventions and rehabilitation: a review study," *Annual Review of Biomedical Engineering*, vol. 9, pp. 351–387, 2007.
- [21] C. Keroglou, I. Seimenis, N. V. Tsekos, C. Pitris, E. Eracleous, and E. G. Christoforou, "Consideration of geometric constraints regarding MR-compatible interventional robotic devices," in *Proc. of 3rd IEEE/RAS-EMBS International Conference on Biomedical Robotics and Biomechanics*, Tokyo, Japan, September 26–29 2010, pp. 355–360.
- [22] G. Schaeffers, "Testing MR safety and compatibility," *IEEE Engineering in Medicine and Biology Magazine*, vol. 27, no. 3, pp. 23–27, 2008.
- [23] N. V. Tsekos, A. Özcan, and E. Christoforou, "A prototype manipulator for MR-guided interventions inside standard cylindrical MRI scanners," *ASME Journal of Biomechanical Engineering*, vol. 127, pp. 972–980, 2005.
- [24] E. G. Christoforou, N. V. Tsekos, and A. Ozcan, "Design and testing of a robotic system for MR image-guided interventions," *J. of Intelligent and Robotic Systems*, vol. 47, no. 2, pp. 175–196, 2006.
- [25] R. J. Webster, "Design and mechanics of continuum robots for surgery," PhD Thesis, Mechanical engineering, The Johns Hopkins University, Baltimore, MD, 2007.
- [26] H. Su, D. C. Cardona, W. Shang, A. Camilo, G. A. Cole, D. C. Rucker, R. J. Webster, and G. S. Fischer, "A MRI-guided concentric tube continuum robot with piezoelectric actuation: a feasibility study," in *Proc. of IEEE Int. Conference on Robotics & Automation*, 2012.
- [27] I. Seimenis, N. V. Tsekos, C. Keroglou, E. Eracleous, C. Pitris, and E. G. Christoforou, "An approach for preoperative planning and performance of MR-guided interventions demonstrated with a manual manipulator in a 1.5T MRI scanner," *Cardiovasc Intervent Radiol*, vol. 35, no. 2, pp. 359–367, 2012.