

# PERSONAL DIALYSIS USING A WEB-BASED, PORTABLE SYSTEM

## *C-PAK (Carry-on Pulse Artificial Kidney)*

Jung Chan Lee, Wook Eun Kim, Ki Moo Lim, Jeong Chul Kim

*Interdisciplinary Program in Medical and Biological Engineering Major, Seoul National University, Seoul, Korea  
ljch@snu.ac.kr, wekim@bme.snu.ac.kr, anzuk7@snu.ac.kr, jckim80@snu.ac.kr*

Byoung Goo Min

*Department of Biomedical Engineering, Seoul National University, Seoul, Korea  
bgmin@snu.ac.kr*

**Keywords:** Hemodialysis, Hemofiltration, Artificial Kidney, Web-based Remote Monitoring.

**Abstract:** While the number of patients suffering from acute and chronic renal failure has been steadily increasing every year, the mortality rate is not improving. For the purpose of improvement on the quality of life and mortality of renal disease patients, we employ the hemofiltration principle to treat the end-stage renal disease patients. Hemofiltration equipment can be installed without additional plumbing and electrical power construction; operated only with several pre-packaged fluid bags without a huge water treatment facility. This paper describes the development of portable renal treatment equipment based on hemofiltration treatment, Carry-on Pulse Artificial Kidney (C-PAK), and reports the results of animal test using the equipment. The web-based remote monitor/control system for C-PAK is introduced also. We expect that our portable hemofiltration device for chronic renal failure patient would be an alternative for conventional hemodialysis machine and a solution to home renal treatment.

## 1 INTRODUCTION

While the number of patients suffering from acute and chronic renal failure has been steadily increasing every year, the mortality rate is not improving. According to theUSRDS (United States Renal Data System), 20% of the inpatients to intensive care unit of hospitals suffer from acute renal failure. The mortality of renal disease patients with other complications has reached 50-80%. Because the number of patients increases over 6% by annually, we expect the population of renal failure to nearly double in 10 years. However, the number of nurses and physicians who treat the increasing number patients is already insufficient. (Rayner, 2000)

The dramatically increasing number of renal disease patients will be a financial burden to the medical insurance. Nowadays, a patient who is treated with in-center renal treatments costs US\$68,400 per year in the United States. (McFarlane, 2002, Mohr, 2001)

Although renal replacement treatment have been developed for a long time after Kolff introduced the hemodialysis in 1943, patients with end-staged renal disease have an average life expectancy of only 5 years and their quality of life is extremely poor. (Jaber, 2004)

For the purpose of improvement on the quality of life and mortality of renal disease patients, we employ the hemofiltration principle to treat the end-stage renal disease patients. Several researchers have already reported their clinical results of this convective treatment. However, simple replacement of conventional hemodialysis or peritoneal dialysis is meaningless. We expect that the patients suffering from end-stage renal failure will be able to choose the flexible treatment method and schedule. Also the patient should be treated with the renal treatment wherever and whenever upon patient's request. A drastic switch from in-center conventional dialysis policy to home renal treatment is necessary. Instead of standardized renal treatment with fixed dose, a treatment with adequate dose for each patient must

be employed with personalized renal treatment equipments.

Hemofiltration, the filtration of the native kidney, has improved the clearance of intermediate-sized molecules that are insufficiently removed by hemodialysis. In particular, beta2-microglobulin, which causes hemodialysis-related amyloidosis within several years of hemodialysis treatment, can be removed effectively by hemofiltration treatment. In addition, hemofiltration treatment is strongly associated with better cardiovascular stability. Moreover, comparison studies supported the claims of reduced mortality of end-staged renal disease patients given hemofiltration treatment. (Jaber and Zimmerman, 2004)

Hemofiltration equipment can be installed without additional plumbing and electrical power construction; operated only with several pre-packaged fluid bags without a huge water treatment facility.

In this paper, we describe the development of portable renal treatment equipment based on hemofiltration treatment, Carry-on Pulse Artificial Kidney (C-PAK), and report the results of animal test using the equipment. We also introduce the web-based remote monitor/control system for C-PAK.

## 2 METHODS

### 2.1 Design of Portable Hemofiltration System

C-PAK is designed for hemofiltration treatment. C-PAK consists of the control panel, the driving panel, the disposable set and the electrical power/control unit. (Figure 1-2)

The control panel includes several function keys and a colour touch screen. All operation is available using pop-up menu on the touch screen. The function keys are used in unexpected case, i.e. when the touch screen is not working correctly. During the treatment, the blood flow rates, the replacement flow rates, the effluent flow rates, the replacement fluid remains, the effluent volume, the total treatment time, and the remaining treatment time are displayed on touch screen.

The driving panel consists of four pumps, several sensors, and a safety gadget. Pump unit includes the dual pulsatile blood pump, the replacement fluid pump, the effluent fluid pump, and the anti-coagulation pump. The sensor unit includes the blood detector, the air-bubble detector, the access pressure sensor, the pre-filter pressure sensor, the

return pressure sensor, the effluent pressure sensor, the blood leak detector, the replacement fluid weight, and the effluent fluid weight. The safety gadget is the tube clamp.

The electrical power/control unit consists of the power supply, the several motor drivers, and the main controller including the microprocessor. During the treatment, the main controller manages several motor drivers, calculates the remained treatment time according to the received data from each sensor and then sends the data and graphs to display on the touch screen. Especially, maintaining the body water balance between the replacement fluid and the effluent is the most important role of the main controller.



Figure 1: Design of C-PAK.

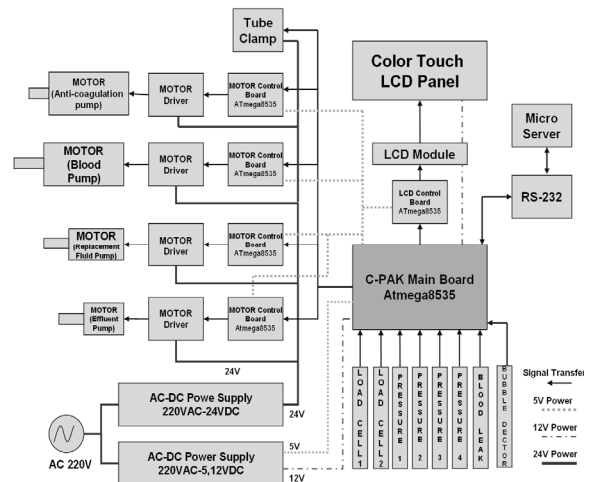

Figure 2: Structure of C-PAK.

## 2.2 Animal Tests of Portable Hemofiltration System

Animal tests (N=13) were prepared to estimate the treatment efficacy of C-PAK. The ligations of renal artery of mongrel dogs weighing  $31.77 \pm 2.53$  kg were performed to induce the renal failure. After ligation surgery, blood urea nitrogen (BUN) concentrations were measured at 12-hr interval. When BUN exceeds 60 mg/dl, the animal was treated with hemofiltration treatment. The venovenous catheters were inserted into the jugular vein for vascular access. The dual pulsatile blood pump could maintain the blood flow rates at 100-150 ml/min during hemofiltration treatment and the blood flow rates were monitored by ultrasonic flow meter.

The bloods were sampled at 1-hr interval. When the exchange volume was achieved, last blood sample was collected and the test was terminated. BUN, creatinine, electrolytes, packed cell volume (PCV), fibrinogen (FIB), total protein (TP), red blood cell (RBC), white blood cell (WBC), glucose, activated partial thromboplastin time (aPTT), and prothrombin time (PT) were measured from blood sampling.

All measured parameters were expressed as means  $\pm$  standard deviation. The adequate efficacy line was defined as  $Kt/V > 0.40$  for daily renal treatment.

## 2.3 Web-based Remote Monitor/Control System for Portable Hemofiltration System

Web-base remote monitor/control system forms a network to connect the patient, his or her medical personnel, and C-PAK.. Embedded system with ARM processor is developed as micro sever, and a communication protocol organizes the network between the micro sever and the main server. Without any restriction of time and place, the medical personnel can access to the main server to monitor the treatment status of the patient and the device in order to send prescriptions with adequate dose for the patient via micro sever. Also, patients can connect to the main servers to check the treatment efficacy and the prescriptions transferred from their medical personnel. (Figure 3-5)

Main server is working with Redhat Linux 9.0 (Red Hat, Inc.) as operating system with Apache/Tomcat server for web service and with MySQL server for database service. Micro server which is directly connected to C-PAK sends the

status of both patient and device to the main server through network.

Micro sever is designed with Net+50 system (NetSilicon, Inc.) based on ARM7 processor and Ethernet controller. ThreadX (Express Logic, Inc.) is employed as an embedded real-time operating system (RTOS) of micro server. RS-232 port of C-PAK was employed for a connection of C-PAK with micro server.

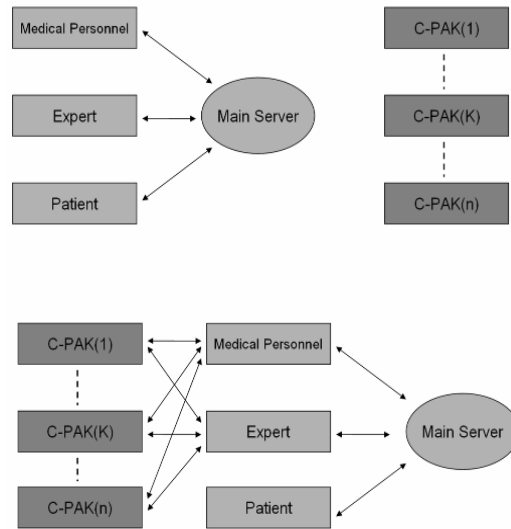

Figure 3: Network structure of web-based monitor-control system for portable hemofiltration system.

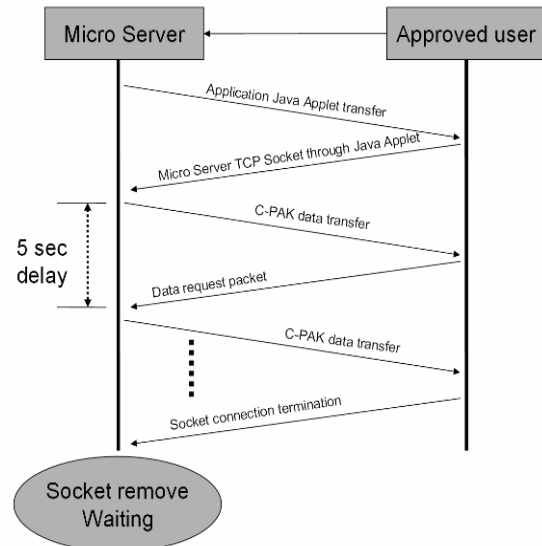

Figure 4: Data transfer protocol between micro server and main server.

### 3 RESULTS

The prototypes of C-PAK were manufactured and in total of 13 animal test cases were performed using C-PAK. Treatment time was  $221 \pm 41$  min, and achieved exchange volume was  $8.98 \pm 2.79$  l. Kt/V was  $0.40 \pm 0.14$ .

The web-based remote monitor/control system was built with a main server and micro servers. C-PAK was connected to a micro server via RS-232 connection. Although web-based remote monitor/control system could not be tested during animal tests, the monitored data transferring test and the remote control test were successfully performed with virtual treatment environment.

System One (NxStage Medical, Inc.) is the only commercialized hemofiltration device for home use. However, our device can meet lighter weights (less than 15kg) than System One (about 35kg).

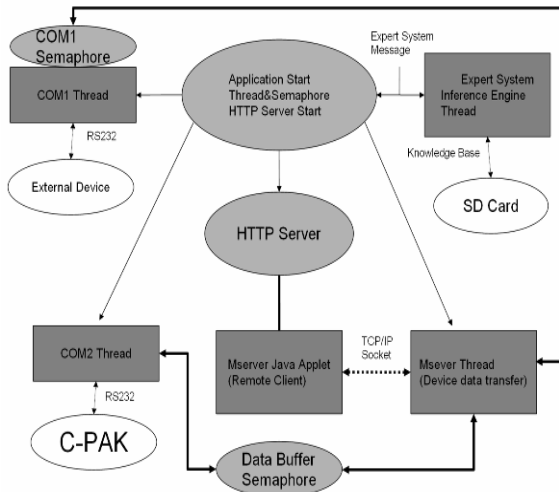

Figure 5: Data transfer scheme of micro server.

### 4 CONCLUSIONS

C-PAK achieved the sufficient treatment efficacy for daily renal treatment in animal tests. The web-based remote monitor/control system will be integrated into the home/portable hemofiltration system.

We expect that our portable hemofiltration device for chronic renal failure patient would be an alternative for conventional hemodialysis machine and a solution to home renal treatment.

### REFERENCES

Rayner, H., Pisoni, R., Bommer, J., Canaud, B., Hecking, E., Locatelli, F., Piera, L., Bragg-Gresham, J., Feldman, H., Goodkin, D., Gollespie, B., Wolfe, R., Held, P., Port, F., 2000. Mortality and hospitalization in haemodialysis patients in five European countries: results from the Dialysis Outcomes and Practice Patterns Study (DOPPS). *Nephrol Dial Transplant*.

McFarlane, P., Pieraatos, A., Redelmeier, D., 2002. Cost savings of home nocturnal versus conventional in-center hemodialysis. *Kidney Int*.

Mohr, P., Neumann, P., Franco, S., Marainen, J., Lockridge, R., Ting, G., 2001. The case for daily dialysis: Its impact on costs and quality of life. *Am J Kidney Dis*.

Jaber, B., Zimmerman, D., 2004. Rationale and experience with short daily hemofiltration. *Semin Dial*.