

An Autonomous, Broadband, Multi-channel Neural Recording System for Freely Behaving Primates

Michael D. Linderman*, Vikash Gilja[†], Gopal Santhanam*, Afsheen Afshar*[§],
Stephen Ryu*[¶], Teresa H. Meng*, Krishna V. Shenoy*[†]

*Department of Electrical Engineering [‡]Department of Computer Science

[§]School of Medicine [¶]Department of Neurosurgery [†]Neurosciences Program
Stanford University, Stanford, California, USA

Abstract—Successful laboratory proof-of-concept experiments with neural prosthetic systems motivate continued algorithm and hardware development. For these efforts to move beyond traditional fixed laboratory setups, new tools are needed to enable broadband, multi-channel, long duration neural recording from freely behaving primates. In this paper we present a dual-channel, battery powered, neural recording system with integrated 3-axis accelerometer for use with chronically implanted electrode arrays. The recording system, called HermesB, is self-contained, autonomous, programmable and capable of recording broadband neural and head acceleration data to a removable compact flash card for up to 48 hours.

I. INTRODUCTION

The development of chronically implanted electrode arrays for *in vivo* neural recording have enabled a range of advances, particularly in the field of neural prosthetics. However, current state of the art experimental systems require the animal to be restrained, limiting both the types and duration of experiments. To make the transition to continuous use in freely behaving subjects, the domain where neural prosthetic systems will ultimately be used, long duration, broadband (sampled at 30 kS/s) neural recordings from freely behaving subjects are needed.

These datasets will enable validation of spike sorting and decoding algorithm performance in freely behaving subjects, multi-day plasticity and learning experiments and direct measurement of the stability, or lack thereof, of neural recordings. Current prosthetic systems typically assume stable neural recordings up to some arbitrary training interval. Long duration broadband datasets can be used to quantify changes in neural recordings, and design principled adaptive spike sorting algorithms that improve neuron tracking and increase prosthetic performance.

A few recording systems have been developed for freely behaving animals [1]–[3]. However, these systems often present one or more of the following limitations: 1) they cannot sample at full broadband (30 kS/s) potentially missing relevant signal

This work was supported in part by MARCO Center for Circuit & System Solutions (T.H.M.,M.D.L.), NDSEG (M.D.L.,V.G.,G.S.) and NSF (V.G.,G.S.) fellowships, Bio-X Fellowship (A.A.), Christopher Reeve Paralysis Foundation (S.I.R.,K.V.S) and the following awards to K.V.S.: NSF Center for Neuromorphic Systems Engineering at Caltech, ONR Adaptive Neural Systems, Whitaker Foundation, Center for Integrated Systems at Stanford, Sloan Foundation, and Burroughs Wellcome Fund Career Award in the Biomedical Sciences. Please address correspondence to mlinderm@stanford.edu.

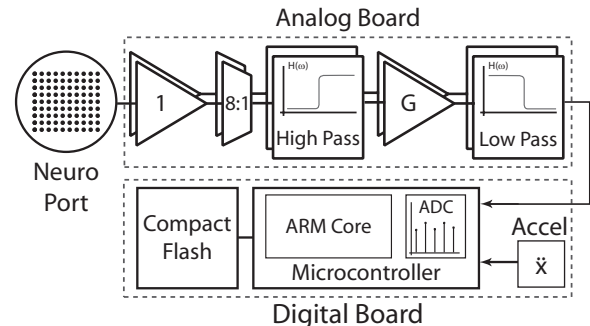

Fig. 1. HermesB system block diagram. The neuroport is a custom 96 channel zero insertion force connector which mates to the electrode array connector. The analog signal conditioning and digitization and storage are implemented on separate circuit boards to reduce noise and provide modularity.

features, 2) their battery life or storage capacity is limited to a few hours or less for broadband recording and 3) they cannot switch recording parameters, such as input channel, autonomously, limiting the range of possible experiments. The HermesB neural recording system addresses these limitations by providing a broadband, long duration, autonomous recording platform for use with electrode arrays chronically implanted in primates.

In this paper we described the first generation of the HermesB neural recording system. The HermesB system comprises a specially designed array connector, analog signal conditioning board and digital data acquisition board with integrated accelerometer. The data is stored on a high capacity non-volatile compact flash (CF) card, which is periodically removed and downloaded to a PC. The system is powered by a pair of high efficiency batteries and housed in a protective casing attached to the monkey's skull.

II. SYSTEM ARCHITECTURE AND IMPLEMENTATION

Figure 1 shows the HermesB system block diagram. HermesB is composed of three separate units, a low profile 96-channel zero insertion force (ZIF) “neuroport,” connector, an analog signal conditioning printed circuit board (PCB) and a digital signal acquisition and recording PCB with compact flash (CF) header.

The HermesB system is architected to be a flexible and extensible experimental platform. The modular construction allows new components, such as experimental analog front

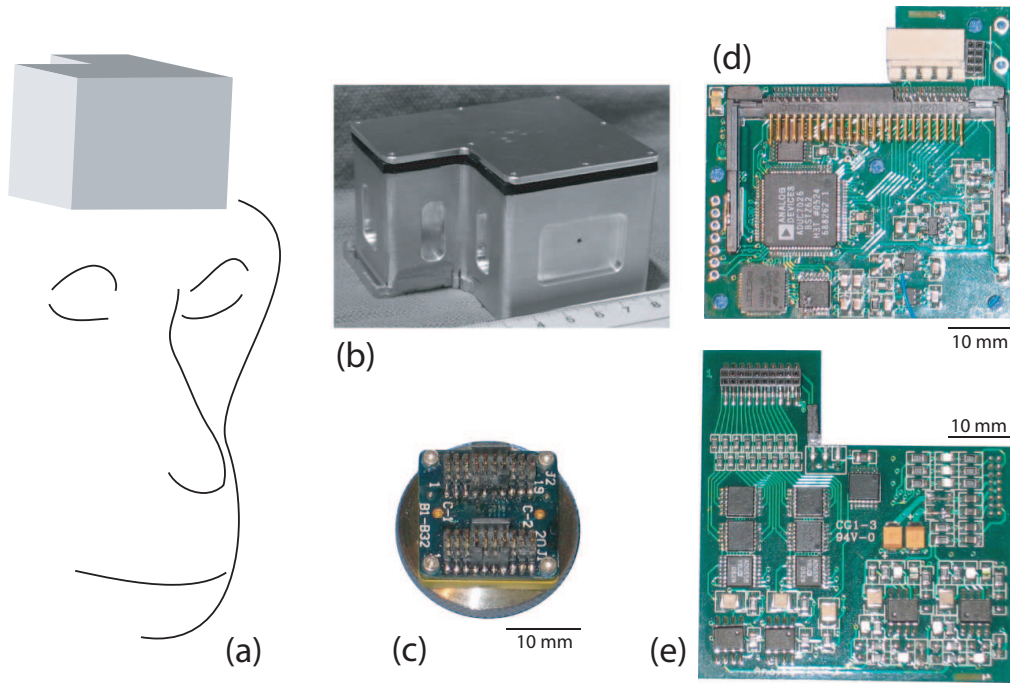

Fig. 2. HermesB system components: (a) illustration of enclosure mounted on monkey's head, (b) aluminum enclosure, (c) custom low-profile neuroport connector, (d) digital board, and (e) analog board.

ends [4] or neural decoding backends, to be incorporated into the system without extensive redesign. Additional ADC channels are provided to support new analog data sources, such as chronically implanted electromyogram (EMG) electrodes. The commercial-off-the-shelf (COTS) CF interface leverages increasing CF Type I card capacity without redesign or re-manufacturing. Table I summarizes system parameters.

A. Physical construction

The system is housed in a protective aluminum case, shown in Figs. 2a,b, embedded in methyl methacrylate, which is in turn secured to the skull. The case encapsulates all of the electronics, batteries, and neuroport connector. The enclosure is sealed with a watertight gasket and is grounded to provide electromagnetic (EM) shielding.

B. Neural implant and connector

Although capable of interfacing with any electrode array, the current HermesB system is designed to work with the 96 channel chronic electrode array manufactured by Cyberkinetics Neurotechnology Systems Inc. (CKI) [5]. The array is wired to a CerePort™ connector pedestal. A custom low profile ZIF connector was developed to mate to the pedestal. The new connector brings 32 of the 96 channels, along with reference electrodes, to headers on an interchangeable PCB.

C. Analog signal conditioning

Figure 1 shows the analog signal conditioning path. Two identical signal paths are provided to amplify and filter two of the 16 input channels. All 16 input channels undergo impedance conversion using a CMOS op-amp (TLC2254) in

TABLE I
HERMESB SYSTEM PARAMETERS

Interface Capabilities	
Simultaneous active channels	2
Programmably accessible channels	16
Connector accessible channels	96
3-axis accelerometer range	$\pm 6g$
Storage	currently 6 GB
Physical Parameters	
Enclosure size	60x70x45 mm
Enclosure mass	127 g
Electronics mass incl. batteries	77 g
Neuroport mass	16 g
Signal Conditioning Parameters	
High pass filter (-3dB)	< .5 Hz
Low pass filter (-3dB)	7.4 kHz
Neural sampling rate	30 kSamples/s
Accel. sampling rate	1 kSamples/s
ADC Precision	12 bits
Battery Parameters	
Battery Capacity	1600 mAh
Typical Battery Life at 67% recoding duty cycle	19 hrs
Measured Circuit Parameters	
Input referred noise	$3.5\mu\text{V RMS}$
Input referred precision	$1\mu\text{V per LSB}$

a unity gain configuration. The desired channels are selected using two 8:1 analog multiplexers (ADG658). The selected signals are high-pass filtered to remove electrode DC bias, then amplified with a differential instrumentation amplifier (INA121). Three path matched references are provided, two reference signals and analog ground, selectable via jumper. The amplified signal is further amplified and low-pass filtered (OPA2344) before being passed to the digital board.

```

% Initial 600 sec. sleep period followed
% by loop of 300 sec. of recording from
% channels 4 & 6 and 150 sec. of sleep
addsleep 600           % Line 0
addsample 4 6 300     % Line 1
addsleep 150          % Line 2
addloop 1             % Line 3

```

Fig. 3. Sample program for autonomous execution. The initial sleep period is added to allow the experimenters sufficient time to close up the protective enclosure before recording commences.

D. Digital signal acquisition

Figure 1 shows the digital module of HermesB. An ARM microcontroller (ADUC2106) is responsible for system control, digitization of the neural and accelerometer signals, and management of the CF card. The analog signals are digitized by a 12-bit successive approximation ADC integrated into the microcontroller. Data packets are buffered using the internal memory of the microcontroller, and written to the CF card. The 3-axis accelerometer (STM9321) is mounted on the digital board to measure the subject’s head movement.

E. Firmware

The HermesB system is controlled by custom firmware. The software includes a basic command interpreter that allows the user to interact with the system in real time when tethered, or write simple sequencing programs for autonomous execution. A sample program is shown in Fig. 3. Program controllable parameters include the acquisition channels, acquisition time and sleep time before next acquisition.

III. EXPERIMENTAL RESULTS AND SYSTEM VERIFICATION

A. Sample Recordings

Figure 4 shows example data recorded from an adult macaque monkey freely moving in a home cage. The HermesB system recorded from a CKI electrode array chronically implanted in dorsal premotor (PMd) cortex¹. The top traces, Fig. 4(a), show the three-axis acceleration of the monkey’s head over a 10s period. This data segment was recorded in the early evening, during a period in which the monkey was clearly quite active.

Figure 4b shows 100 ms of broadband neural data recorded from a single channel on the electrode array. The low frequency oscillations (LFP) are easily visible, as are a number of spikes “riding” on top of the LFP. Figure 4c shows the same data segment filtered with a 250 Hz high pass IIR filter.

B. Verification

Datasets, like that shown in Fig. 4, were used as part of a three step verification process to ensure the accuracy of HermesB recordings. The steps were 1) measure HermesB circuit parameters, 2) compare recordings of the CKI Neural Simulator made with HermesB and our standard fixed laboratory recording system (CKI Cerebus System) and 3)

¹Surgical methods described in [6], [7]. All experiments and procedures were approved by the Stanford University Institutional Animal Care and Use Committee (IACUC).

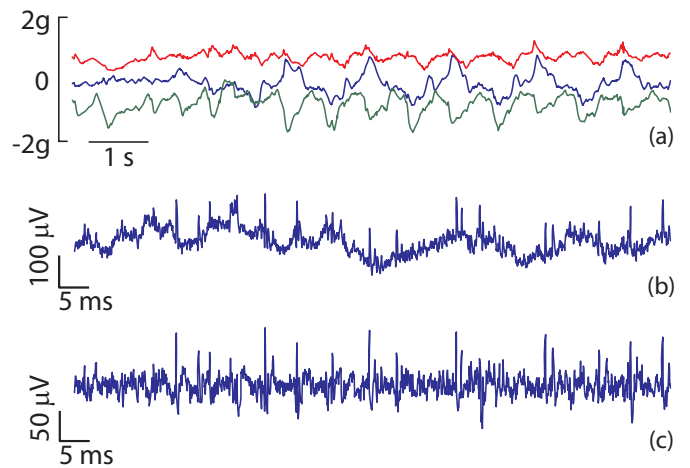

Fig. 4. Sample neural and accelerometer data recorded from a freely behaving monkey. (a) Accelerometer data (b) unfiltered broadband neural data taken from the middle of the recording period and (c) filtered broadband neural data.

compare HermesB recordings of neural activity in a monkey to recordings made by the fixed laboratory system.

The measured circuit parameters are summarized in Table I. The input referred noise, measured with grounded inputs, is comparable to or better than current state-of-the-art commercial and research systems [4], [5].

The CKI Neural Simulator is a neural recording playback device that provides 128 channels of simulated neural signals at typical amplitudes for array recordings ($\sim 500 \mu\text{Vpp}$). Figure 5a shows a side-by-side comparison of Neural Simulator recordings made with the HermesB system (right) and with the CKI Cerebus system (left). The three spike waveforms are clearly visible, with comparable levels of noise (measured as the spread of the curves) between the two systems.

Figure 5b shows a similar comparison for an example neural channel recorded from a monkey sitting quietly in a primate chair. The figure shows the 10th–90th percentile in amplitude of action potential waveforms recorded from a single channel on the electrode array. A five minute recording was sorted using the Sahani algorithm which classified the spikes as belonging to one of four units (indicated by different coloring) [8], [9]. The waveforms are very similar between the two systems, indicating, along with the other tests, that the recording accuracy of the HermesB system is comparable to current state-of-the-art laboratory equipment.

C. Experiment Protocols

A number of experiment protocols are currently in use. An example protocol is to record at a 67% duty cycle² (five minutes of recording followed by 2.5 minutes of sleep) for approximately 54 hours, broken up into three 18 hour sessions. Between each session, the monkey is transferred from the

²The duty cycling is a compromise between memory capacity and battery life constraints. When recording continuously the current memory capacity is quickly exhausted, while at low duty cycling the battery is discharged by the static power consumption before the CF card is full, despite sleeping the microcontroller in between recording blocks.

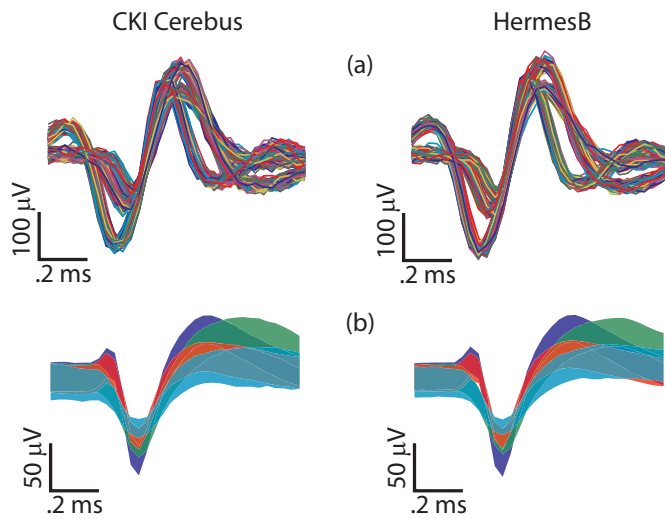

Fig. 5. Comparison of snippets recorded with CKI Cerebus system (left) and HermesB system (right). (a) Snippets recorded from CKI Neural Simulator. (b) Snippets from four neurons recorded from a single electrode channel in a restrained monkey. Snippets have been sorted and the 10th–90th percentile in amplitude indicated by the colored region for each waveform.

home cage to the training chair to replace the battery, and download the ~ 4 GB of recorded data. During these “pit stops,” recording is continued with a second smaller CF card and new battery to maintain dataset continuity. Other protocols in use are round-robin recording of 4 and 8 channels using a 24 hour schedule.

IV. DISCUSSION

The high quality of the broadband recordings, even in the electrically noisy home cage room, enables results from the HermesB system to be integrated into experiments using the traditional laboratory rig. The long duration recordings, in concert with traditional experiments, enable important multi-day learning and plasticity experiments. Researchers can use HermesB to record during periods when the animal is outside the rig to provide continuous monitoring of significant neurons identified during active experiments. Currently, without such monitoring, it is not possible to certify that the same neuron is being observed day-to-day.

Long duration, continuous broadband recording with integrated head acceleration allows direct measurement of neural recording stability. Activity dependent waveform change, electrode drift and non-stationary background noise processes can affect neural recordings and therefore potentially impair spike sorting [10]. These variations occur over a range of time scales, from the inter-spike interval to days or even months. However, current recording tools are limited to characterizing changes only at very short (seconds to minutes) or very long timescales (day-to-day). The HermesB system makes possible characterization of neural recordings over intermediate timescales (2–24 hours). The broadband recordings enable studies of the background noise process and short timescale activity dependent spike waveform change. The accelerometer can be used to identify, and correlate to recorded signals, movements that could cause electrode shift.

V. CONCLUSION

In this paper we have described the HermesB system, a new, self-contained, long duration, neural recording system for use with freely behaving primates. The HermesB system records dual channel broadband and 3-axis head acceleration data to a high density compact flash card. Controlled by simple sequencing programs written by the experimenter, the HermesB system can autonomously change recording channel and pause recording during the experiment. With a single battery charge HermesB can record for up to 48 hours (at a low duty cycle). With short breaks to replace the batteries and compact flash card, the HermesB system can record nearly continuously for an indefinite period.

The HermesB system is currently in active use supporting a number of experiments, which will be described in future publications [11], [12], as well as ongoing development to increase recording capabilities. As CF technology and battery energy density improves, recording density and duration will be expanded. Future generations of the HermesB system will also incorporate wireless telemetry and more simultaneous recording channels.

ACKNOWLEDGMENT

The authors would like to thank Shane Guillory of In-tractographix, who designed and laid out the analog module and laid out the digital module, Jim McCrae, Karlheinz Merkle, Pascal Stang and Carter Dunn for their help designing and manufacturing HermesB and Mackenzie Risch for expert veterinary care.

REFERENCES

- [1] A. L. Vysotki, *et al.*, “Miniature neurologgers for flying pigeons: Multichannel eeg and action and field potentials in combination with gps recording,” *J. Neurophysiol.*, vol. 95, pp. 1263–1273, 2006.
- [2] J. Mavoori, A. Jackson, C. Diorio, and E. Fetz, “An autonomous implantable computer for neural recording and stimulation in unrestrained primates,” *J. Neuroscience Methods*, vol. 148, pp. 71–77, 2005.
- [3] I. Obeid, M. A. L. Nicolelis, and P. D. Wolf, “A multichannel telemetry system for single unit neural recordings,” *J. Neuroscience Methods*, vol. 133, pp. 33–38, 2004.
- [4] R. Harrison, *et al.*, “A low-power integrated circuit for a wireless 100 electrode neural recording system,” in *Proc. of ISSCC*, 2006, pp. 554–555.
- [5] [Online]. Available: <http://www.cyberkineticsinc.com>
- [6] N. Hatsopoulos, J. Joshi, and J. G. O’Leary, “Decoding continuous and discrete behaviors using motor and premotor cortical ensembles,” *J. Neurophysiol.*, vol. 92, pp. 1165–1174, 2004.
- [7] M. Churchland, *et al.*, “Neural variability in premotor cortex provides a signature of motor preparation,” *J. Neuroscience*, vol. 26, pp. 3697–3712, 2006.
- [8] M. Sahani, “Latent variable models for neural data analysis,” Ph.D. dissertation, California Institute of Technology, 1999.
- [9] Z. S. Zumsteg, *et al.*, “Power feasibility of implantable digital spike sorting circuits for neural prosthetic systems,” *IEEE Trans. Neural Syst. Rehab. Eng.*, vol. 13, pp. 272–279, 2005.
- [10] M. S. Lewicki, “A review of methods for spike sorting: the detection and classification of neural action potentials,” *Network: Comput. Neural Syst.*, vol. 9, pp. R53–R78, 1998.
- [11] M. D. Linderman, *et al.*, “Neural recording stability of chronic electrode arrays in freely behaving primates,” in *Proc. of Conf. of IEEE EMBS*, 2006, submitted.
- [12] V. Gilja, *et al.*, “Multiday electrophysiological recordings from freely behaving primates,” in *Proc. of Conf. of IEEE EMBS*, 2006, submitted.