

An Optical Fiber Photoplethysmographic System for Central Nervous System Tissue

Justin P. Phillips, Panayiotis A. Kyriacou, *Member, IEEE*, Kuriakose J. George, John V. Priestley, and Richard M. Langford.

Abstract—A new system for measuring the oxygen saturation of blood within tissue has been developed, for a number of potential patient monitoring applications. This proof of concept project aims to address the unmet need of real-time measurement of oxygen saturation in the central nervous system (CNS) for patients recovering from neurosurgery or trauma, by developing a fiber optic signal acquisition system for internal placement through small apertures. The development and testing of a two-wavelength optical fiber reflectance photoplethysmography (PPG) system is described. It was found that good quality red and near-infrared PPG signals could be consistently obtained from the human fingertip (n=6) and rat spinal cord (n=6) using the fiber optic probe. These findings justify further development and clinical evaluation of this fiber optic system.

I. INTRODUCTION

NONINVASIVE arterial blood oxygen saturation measurement by pulse oximetry is widely recognized as one of the most important technological advances in clinical monitoring [1]. Although generally reliable, the use of transmission pulse oximeter probes is limited to peripheral parts of the body such as the finger, toe or ear lobe.

An attempt to measure blood oxygen saturation at other sites than the periphery was recently made by Kyriacou *et al* with the development of a reflectance opto-electronic esophageal pulse oximeter [2]. The measurement of arterial oxygen saturation using the principle of reflectance pulse oximetry, which measures the intensity of light backscattered from the tissue, was first described by Mendelson and Ochs [3]. Studies using the reflectance esophageal pulse oximetry system have shown that measurable PPG signals and SpO₂ values can be detected in the esophagus of healthy adult patients during anesthesia. The esophageal blood oxygen saturation (SpO₂) values showed good agreement with results from

commercial finger pulse oximetry probes and CO-oximetry. A further study in patients undergoing cardiac surgery showed that reliable esophageal SpO₂ readings could be obtained during periods when finger probes failed due to poor peripheral perfusion [4]. Despite its successful performance, the size of the esophageal probe limits its application in areas such as a brain or other small cavities.

A number of internal monitoring applications require further miniaturization, indicating the need for coupling of the light sources and photodetector to optical fibers. In addition to enhanced accessibility to a wider range of internal sites, optical fibers have the advantage for patient safety of complete electrical isolation. Optical fibers are already used for many clinical applications including oximetry, most notably for measuring the oxygen saturation of whole blood within large blood vessels [5]. Externally applied optical fiber pulse oximeters are used routinely to monitor patients in magnetic resonance imaging (MRI) scanners in which conducting components cannot be used due to the high electromagnetic field strengths [6].

A serious concern in the treatment of patients after major neurosurgical procedures and particularly in the days after traumatic head injury is to prevent secondary damage from raised intracranial pressure (ICP) due to swelling of the brain or bleeding. Increased intracranial pressure impedes cerebral blood perfusion leading to a damaging lack of oxygen and nutrients and an accumulation of metabolites in the brain [7]. For many years, management of patients at serious risk of raised intracranial pressure has included intracranial pressure monitoring via a burr hole drilled through the skull, in order to facilitate insertion of the pressure transducer itself or a fluid-filled catheter connected to an external transducer. More recently, it has become increasingly common to facilitate such access using cranial bolts, which are screwed into the skull providing a sealed system with minimal risk of fluid leakage or infection [8]. The optical fiber probe we have developed is primarily intended to be inserted via a cranial bolt, allowing oxygen saturation measurements to be made directly from the brain tissue.

A further potential application is the measurement of PPG signals and oximetry measurements from the spinal cord. Patients recovering from spinal cord injury are at risk from secondary injury due to ischemia [9]. An optical fibre probe could provide a clinically useful monitoring modality, giving an indication of blood supply and arterial oxygen saturation within the spinal cord. It is envisaged that the fibres could be

Manuscript received April 3, 2006.

J. P. Phillips is with the Anaesthetic Laboratory, St Bartholomew's Hospital, London, EC1A 7BE, UK (phone: 0044-20-7601-7527; fax: 0044-20-7601-7528; e-mail: j.p.phillips@qmul.ac.uk).

P. A. Kyriacou is with the School of Engineering and Mathematical Sciences, City University, London, EC1V 0HB, UK (e-mail: p.kyriacou@city.ac.uk).

K. J. George was with the Neuroscience Centre, Queen Mary, University of London, E1 0NS, UK (email: k.joshigeorge@yahoo.co.uk).

J. V. Priestley is with the Neuroscience Centre, Queen Mary, University of London, E1 0NS, UK (email: j.v.priestley@qmul.ac.uk).

R. M. Langford is with the Anaesthetic Laboratory, St Bartholomew's Hospital, London, EC1A 7BE, UK (e-mail: r.m.langford@btconnect.com).

inserted into the epidural space via an epidural needle and left in place for the duration of the monitoring period.

To undertake the challenge of exploring new pulse oximetry technologies and monitoring sites, the present study was aimed at developing and evaluating the reliability of a new fibre optic brain tissue reflectance pulse oximeter used for critically ill patients. The technological developments of such a pulse oximeter probe and preliminary results from evaluating the new probe on the finger and on the rat spinal cord dura will be presented.

II. METHOD

The optical fiber oximetry system comprises three main parts:

A. Probe

The probe consists of two parallel silica optical fibers (SpecTran Speciality Optics, Avon, CT, USA) with a core diameter of 400 μm , an outer cladding diameter of 730 μm and a numerical aperture (NA) of 0.39. Each fiber is terminated at one end with an SMA connector and the other end is cut and polished flat. The fibers are coated in a protective PVC jacket, which is stripped away over a length of several centimetres from the un-terminated end. The two optical fibers are held a fixed distance apart at the distal end by a plastic molding.

B. Instrumentation

This is housed in an aluminium box containing: light sources; SMA mounted red (660 nm) and infrared (850 nm) LEDs (The Optoelectronic Manufacturing Corporation Ltd, Redruth, UK); a photodetector; an SMA mounted PIN photodiode (The Optoelectronic Manufacturing Corporation Ltd); a power supply (2 x 12 V lead-acid batteries); and, a circuit comprising two switchable regulated current sources connected to the LEDs and a differential transimpedance amplifier, a demultiplexing circuit and filters (to attenuate noise and to separate the ac and dc components of the signal) connected to the photodiode. One optical fiber is connected to the two light sources via a bifurcated optical fiber assembly (Ocean Optics Inc., Dunedin, FL, USA). The other fiber is coupled directly to the photodetector.

C. Data acquisition system

The LEDs are controlled by the digital multiplexing signal from a 16-bit PCMCIA data acquisition card (DAQCard-AI-16XE-50, National Instruments Inc., Austin, TX, USA) installed in a Sony VAIO PCG-Z600HEK notebook computer running a LabVIEW (National Instruments) Virtual Instrument (VI). The VI allows the user to control the multiplexing frequency of the light sources and the sampling frequency. The VI reads each of the two PPG signals at a rate of 100 samples per second, displays the PPG waveform and records both signals in a spreadsheet file. The PPG signal is normalized by dividing by the dc signal for

each wavelength. This is because the ratio PPG ac:dc is used in the algorithms to estimate SpO_2 in pulse oximeters.

A block diagram of the system is shown in Fig. 1.

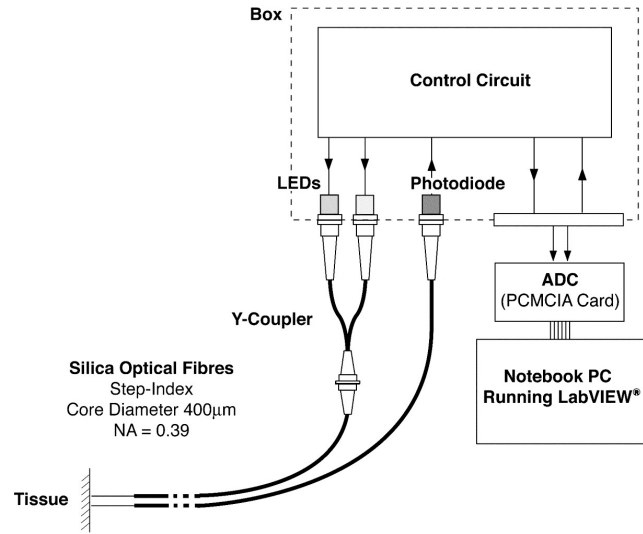

Fig. 1. Block diagram of PPG measurement system.

D. Measurement from finger

The effectiveness of the system for obtaining reliable PPG signals from tissue was first demonstrated by measuring signals from the index finger. The optical fibers were mounted on an optical bench platform so that the lateral separation of the centre of the fibers was fixed at 2.0 mm. This distance was chosen as it is the maximum lateral separation that would be possible if the fibers were inserted into the largest commercially available cranial bolt (Integra Neurosciences Inc., Plainsboro, NJ, USA). The platform could be moved longitudinally by adjusting a thumbwheel located on the platform. A standard pulse oximetry probe shell (Datex-Ohmeda, Helsinki, Finland) was adapted by cutting a rectangular hole, approximately 5 mm by 3 mm, into the shell casing. The probe shell was mounted on the optical bench in such a way that the fibers pass through the hole by a distance determined by the position of the platform. When the finger was inserted into the probe the position of the fibers was adjusted so the fibers were brought in contact with the skin without exerting any significant pressure on the skin.

The apparatus was placed in a room with no artificial light and no direct sun, to minimize interference from stray light entering the photodetector. Measurements were taken from the skin of the left index finger of six subjects. Prior to making any measurements a skin temperature probe (DeRoyal Inc. Knoxville, TN, USA) was affixed to the forefinger with tape as close to the measuring site as possible. The skin temperature was maintained between 31°C and 33°C during the measurements by adjusting the ambient air temperature using a thermostatically controlled fan heater. A continuous PPG signal was recorded for one

minute simultaneously at both the red (660 nm) and infrared (850 nm) wavelengths. During this period the finger was held as still as possible by the subject. The acquired signal was filtered using a 2nd order bandpass Butterworth filter with the passband ranging from 0.39 Hz to 8.0 Hz.

E. Measurement from rat spinal cord

A dedicated optical fiber probe was constructed, consisting of two optical fibers, their centres laterally separated by a distance of 1.0 mm. The fibers were passed along a metal tube attached to a metal bar measuring 4 mm long by 1.5 mm wide. The fiber ends were inserted into the bar so they were flush with the lower surface of the bar as shown in Fig. 2. The lower surface of the bar is curved to fit the contour of the rat spinal cord thus avoiding any localized compression of the tissue. The metal tube was supported within a stereotactic frame so that it can move in the vertical direction only.

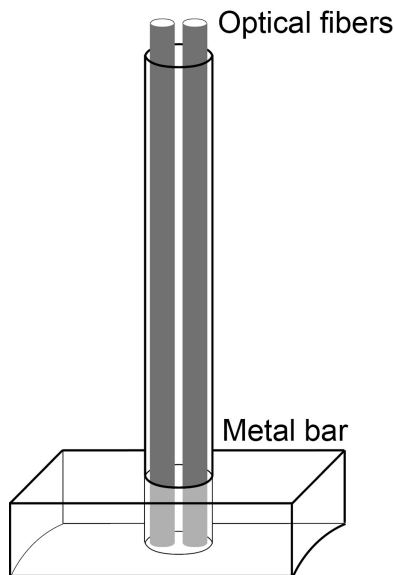

Fig. 2. Apparatus for rat spinal cord PPG measurement.

Six adult female Sprague-Dawley rats, each weighing approximately 250 g were anesthetized using Halothane. A 5 cm skin incision was made along the thoracic spine and dissection was done to expose the underlying spinal column. The laminae of T12 vertebra (approximately 5mm in length) were removed to expose the dura over the underlying spinal cord. The probe was lowered to gently rest on the surface of the spinal cord dura as shown in Fig. 3.

A continuous PPG signal was recorded for one minute simultaneously at both the red (660 nm) and infrared (850 nm) wavelengths. The acquired signal was filtered using a 2nd order bandpass Butterworth filter with the passband ranging from 1.2 Hz to 16.0 Hz. A higher range of frequencies was chosen for this filter than for the human measurements due to the much higher heart rate of the rat compared to the human.

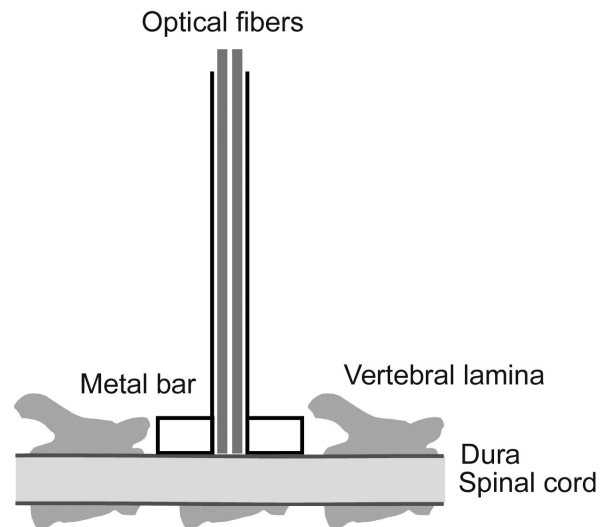
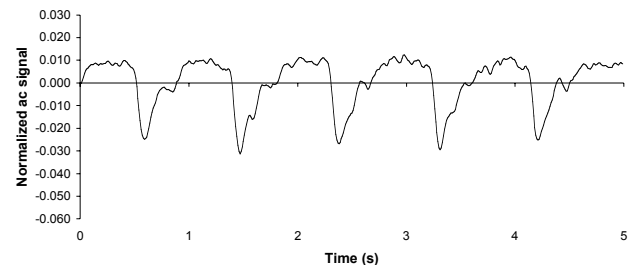

Fig. 3. Apparatus for rat spinal cord PPG measurement *in situ*.

III. RESULTS

A. Measurement from finger

Good quality PPG signals were achieved consistently in all six human studies. Five-second samples of the normalized PPG traces for red (660 nm) and infrared (850 nm) light obtained from the index finger of one subject are shown in Fig. 4. The waveform is well defined at both wavelengths and the dichrotic notch is clearly visible.



(a)

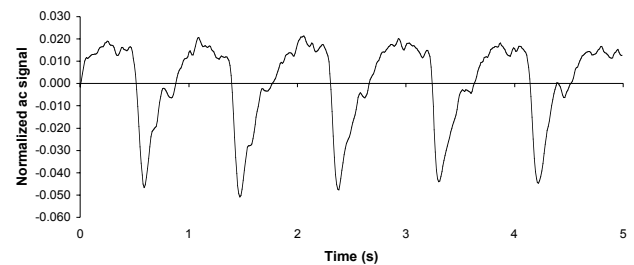

(b)

Fig. 4. (a) Red and (b) infrared PPG traces from the finger.

B. Measurement from rat spinal cord

Good quality PPG signals were also achieved consistently in all six rat spinal cord recordings. Five-second samples of the normalized PPG traces for red (660 nm) and infrared (850 nm) light obtained from the rat spinal cord are shown in

Fig. 5. The waveform is reasonably well defined at both wavelengths. The dichrotic notch and other details are not as clearly defined as in the PPG traces from the finger due to the high heart rate of the rat compared to the human.

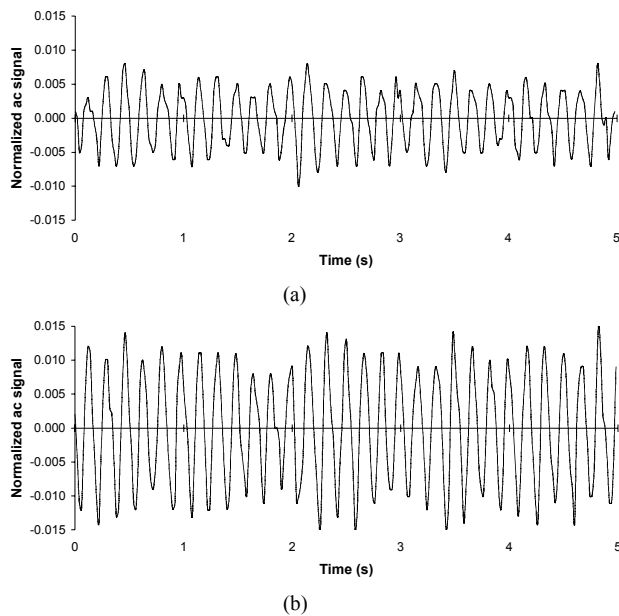

Fig. 5. (a) Red and (b) infrared PPG traces from the rat spinal cord.

IV. DISCUSSION

It was found that good quality red and near-infrared PPG signals could be obtained from the index finger and the spinal cord dura using a fiber optic probe. The lateral separation of the optical fibers may be limited by the maximum diameter of a probe, whose size may be dictated by the intended application. For measurements in the brain, the cranial bolts currently available do not permit a fiber-fiber separation greater than 2 mm. This is sufficient, however, to obtain good quality PPG signals. These results provide justification for the development of an optical fiber measurement system for the brain and other nervous tissue.

The dural membrane in rats is much thinner and therefore more transparent than in the human [10]-[11]. It might therefore be necessary to perforate the dura to make optical measurements from the human brain. Penetration of the dura and the brain itself should not be seen as a deterrent; indeed it is deemed perfectly acceptable and established routine practice to facilitate potentially valuable monitoring, which could reduce the degree of secondary brain damage in these high risk patients.

The brain and spinal cord are two of the most vascular tissues in the human body and also among the most vulnerable to small changes in blood oxygenation. The next stage in the development of this project will be a proof of concept trial in patients undergoing neurosurgery in whom cranial bolts are indicated as part of their routine care. Following this study a more extensive trial will be performed in patients recovering from head injuries. It is

hoped that it will be possible to collect data for 24-48 hours, and that oxygen saturation will be calculated and compared with other modalities such as ICP and arterial oxygen saturation measured peripherally using a finger or ear probe.

REFERENCES

- [1] Y. Mendelson, "Pulse oximetry: theory and applications for noninvasive monitoring," *Clin. Chem.*, vol. 38, no. 9, pp. 1601-1607, Sep. 1992.
- [2] P. A. Kyriacou, S. Powell, R. M. Langford and D. P. Jones, "Esophageal pulse oximetry utilizing reflectance pulse oximetry," *IEEE Trans. Biomed. Eng.*, vol. 49, no. 11, pp. 1360-1368, Nov. 2002.
- [3] Y. Mendelson and B. D. Ochs, "Noninvasive pulse oximetry utilizing skin reflectance photoplethysmography," *IEEE Trans. Biomed. Eng.*, vol. 35, no. 10, pp. 798-805, Oct. 1988.
- [4] P. A. Kyriacou, S. Powell, D. P. Jones and R. M. Langford, "Evaluation of oesophageal pulse oximetry in patients undergoing cardiothoracic surgery," *Anaesthesia*, vol. 58, pp. 422-427, Jan. 2003.
- [5] A. Armaganidis, J.F. Dhainaut, J.L. Billard, K. Klouche, J.P. Mira, F. Brunet, A.T. Dinh-Xuan and J. Dall'Ava-Santucci, "Accuracy assessment for three fiberoptic pulmonary artery catheters for SVO₂ monitoring," *Intensive Care Med.*, vol. 20, no. 7, pp. 484-488, Aug. 1994.
- [6] I. P. West, R. Holmes and G. R. Jones, "Optical fibre based pulse oximeter for monitoring in magnetic resonance scanners," *Proc. of Spie - the Int. Soc. for Opt. Eng.*, vol. 2360, pp. 94-97, Sep. 1994.
- [7] J. Ghajar, "Traumatic Brain Injury," *The Lancet*, vol. 356, pp. 923-929, Sep. 2000.
- [8] R. W. Mortara, "Intracranial monitoring in the emergency setting," *Med. Instrumentation*, vol. 16, no. 4, pp. 197-198, Jul. 1982.
- [9] F. Castro-Moure, W. Kupsky and H.G. Goshgarian, "Pathophysiological classification of human spinal cord ischemia [Review]," *J. of Spinal Cord Med.* vol. 20, no. 1, pp. 74-87, Jan. 1997.
- [10] J. P. Cassella, J. Hay and S.J. Lawson, *The Rat Nervous System: An Introduction to Preparatory Techniques*, New York: Wiley, 1997, pp. 9-14.
- [11] J. Roland, C. Bernard, S. Bracard, A. Czorny, J. Floquet, J. M. Race, P. Forlodou and L. Picard, "Microvascularization of the intracranial dura mater," *Surgical and Radiologic Anatomy*, vol. 9, no. 1, pp. 43-49, Mar. 1987.